

Assembly manual

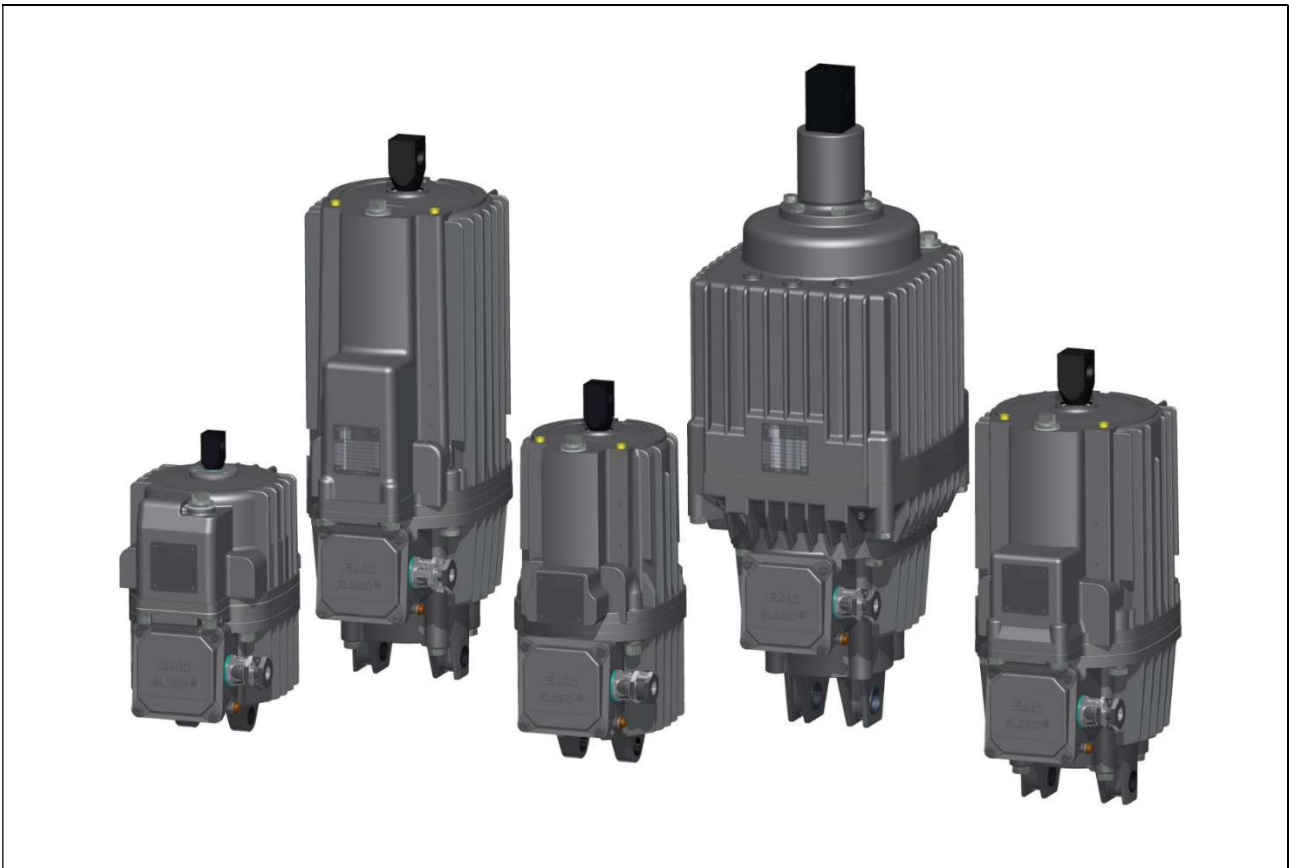

General designation

ELDRO® electro-hydraulic lifting thrusters

Type designation

Ed 12 to Ed 630 standard range and special designs (three-phase voltage version)

Date:

10/2021

Table of contents

1	General.....	6
1.1	Information about this assembly manual	6
1.2	Manufacturer.....	6
1.3	Validity.....	7
1.4	Further applicable documents.....	7
1.5	Formal information about this assembly manual	7
1.6	Format conventions	8
1.7	Structure of warning notices	9
1.8	Terms and abbreviations.....	10
2	Safety	11
2.1	Intended use	11
2.2	Unintended use	12
2.3	Staff qualifications	12
2.3.1	Qualified personnel	13
2.3.2	Qualified electrician	13
2.3.3	Maintenance staff.....	14
2.3.4	Responsible staff.....	15
2.4	Personal protective equipment.....	15
2.5	Electrical equipment	16
2.6	Process media.....	17
2.7	Modifications	17
2.8	Spare and wear parts.....	17
3	Technical data	18
3.1	Type designation and type key.....	18
3.2	Specifications on the type plate	19
3.3	Characteristics	20
3.4	Dimensions	23
3.4.1	Type Ed 12	23
3.4.2	Type Ed 23 to Ed 25	24
3.4.3	Type Ed 30	26
3.4.4	Types Ed 50, Ed 80, Ed 125	28
3.4.5	Types Ed 121 to Ed 501.....	32
3.4.6	Type Ed 350	39
3.4.7	Type Ed 630	41
3.5	Airborne sound emissions.....	42
3.6	Operating conditions	42
3.6.1	Ambient temperature.....	42

3.6.2	Air humidity	43
3.6.3	Aggressive ambient conditions	43
3.6.4	Voltage and frequency tolerances.....	43
3.6.5	Installation height	43
4	Functional description.....	44
4.1	Mechanical layout	45
4.1.1	Type group 1	45
4.1.2	Type group 3	46
4.1.3	Type group 4	47
4.1.4	Type group 5	48
4.2	Electrical equipment	49
4.3	Functional description.....	49
5	Transport and storage.....	50
5.1	Transport.....	50
5.1.1	Transport sketch	51
5.2	Storage	51
6	Assembly and installation.....	52
6.1	Assembly	52
6.1.1	Permissible installation positions	54
6.1.2	Installing the ELDRO® thruster.....	55
6.2	Electrical connection	56
6.2.1	Junction box and terminal diagram	57
6.2.2	Earthing conductor connection.....	60
6.2.3	Power supply connection	60
6.2.4	ELDRO® thrusters with additional heating	61
6.3	Adjusting the valves	63
6.3.1	Adjustment screw installation location	63
6.3.2	Changing the set time and the reset time	64
6.4	Completing assembly	64
7	Notes on operation	65
7.1	Checking the operating conditions prior to starting up	66
8	Help with malfunctions.....	67
8.1	Faults and troubleshooting.....	67
9	Maintenance	69
9.1	Maintenance tasks	69
9.1.1	Operating fluid	71
9.1.2	Checking the operating fluid.....	72
9.1.3	Seals	73

9.2	Maintenance schedule	74
9.2.1	Classification	75
10	Disassembly	76
10.1	Disconnecting the electrical connections	77
10.2	Removal	77
11	Disposal	79
11.1	Disposal consideration.....	79
12	Lists	80
12.1	Index of figures.....	80
12.2	Index of tables	80
13	Appendix	82
13.1	Further applicable documents.....	82

1 General



1.1 Information about this assembly manual

1 General

1.1 Information about this assembly manual

This assembly manual was prepared according to the principles of technical editing and the minimum legal requirements of directive 2006/42/EU are used as a basis. The assembly manual enables the safe and efficient operation of the ELDRO® electro-hydraulic lifting thruster (subsequently referred to as ELDRO® thruster).

This maintenance manual is part of the ELDRO® thruster and must be kept in its immediate vicinity and accessible to staff at all times.

The staff must have read this assembly manual carefully and understood it before starting any work.

Version	Description	Date	Author
V1.0	Draft compiled	08/10/2019	CE Design
V2.0	Special types added	16/01/2020	CE Design
V3.0	Special types added	22/04/2020	EMG
V4.0	Supplementary warning	04/03/2021	EMG
V5.0	Modification Terminal diagram	29/10/2021	EMG

1.2 Manufacturer

EMG Automation GmbH
Industriestr. 1
D-57482 Wenden / Germany

Phone +49 2762 612 0
Fax +49 2762 612 320

E-mail info@emg-automation.com
Internet www.emg-automation.com

1.3 Validity

This manual corresponds to the technical state of the ELDRO® thruster at the time of issue. The contents of this manual are not contractually binding but are provided as information.

EMG Automation GmbH reserves the right to make content and technical changes compared to this manual without having to specify these. EMG Automation GmbH cannot be held responsible for any inaccuracies or incorrect specifications in this manual, which are caused by content and technical changes after delivering this ELDRO® thruster, as there is no obligation to update this manual continually.

1.4 Further applicable documents

All documents listed in the appendix (further applicable documents) to this maintenance manual must be observed.

1.5 Formal information about this assembly manual





© Copyright, 2021

All rights reserved.

Reprinting, including excerpts, is only permissible with the approval of EMG Automation GmbH.

1.6 Format conventions

Table 1: Format conventions

Format	Meaning
1. Action	Action step with a sequence
▪	Action step / user instruction
–	List
"ABC"	Highlighting of special terms in the text
⇒	Reference to chapters or sections of this operating manual or to further applicable documents (e.g ⇒ Technical data chapter)
	This signal word indicates an immediate threat of danger. If this danger is not avoided, this will result in death or serious injuries.
	This signal word indicates a possible danger. If this danger is not avoided, this may result in death or serious injuries.
	This signal word indicates a possibly dangerous situation. If this dangerous situation is not avoided, this may result in minor or moderate injuries.
	This signal word indicates actions for preventing property damage. Observing this information prevents damage or destruction of the ELDRO® thruster.
	Supplementary information

1.7 Structure of warning notices

If observed, warning notices protect against possible personal injury and property damage and classify the extent of the danger by the signal word.

 WARNING = Signal word
Source of danger Possible consequences of non-compliance – Measures for avoidance/prohibited actions

Hazard signs

The hazard sign indicates warning information that alerts you of personal injury hazards.

Source of danger

The source of the danger indicates the cause of the hazard.

Possible consequences of non-compliance

The possible consequences when failing to observe the warning information are bruises, burns or other serious injuries.

Measures/prohibited actions

Measures / prohibited actions contains a list of instructions that must be implemented in order to avoid a hazard or that are prohibited in order to avoid a hazard.

1.8 Terms and abbreviations

The following terms and abbreviations are used in the maintenance manual.

Table 2: Terms and abbreviations

Term/abbreviation	Meaning
Brake spring	Cylindrical pressure spring that counteracts the hydraulic force. As a result, only the force difference on the lifting rod is effective as the actuating force.
Damping spring (d spring)	Spring for gentle braking. This reduces the braking force by applying the brake shoes continuously until the stop value is reached. When bleeding the brake, the braking force reduces continuously from the highest value to zero (releasing the brake shoes).
ELDRO® thruster	Electro-hydraulic lifting thruster that converts electrical energy into mechanical energy in a straight line movement by hydraulic means
Highest value for additional load	Total of the forces that apply to the lifting rod head and that affect the lifting movement and setting time, e.g. friction and mass of the connection elements
Lifting valve H	Valve to reduce the lifting speed
Lifting and lowering valve HS	Valves to reduce the lifting and lowering speeds
Lifting time	Time from switching the motor on until the top piston limit position is reached
Nominal operating point	Operating point that is at 1/3 of the nominal lift
Nominal lift	Maximum path that the extending lifting rod can take
Nominal reset force	Minimum force at the nominal operating point for a machine with reset spring c
Nominal actuating force	Usable hydraulic force on the lifting rod head for a machine without reset spring c
Regulation braking	Braking to regulate three-phase motors to low speeds, virtually independent of the load. A pump wheel with optimum adjustment determines the hydraulic force with the nominal reset force. Thrusters for regulation braking are equipped with reset spring c and damping spring d.
Regulation spring	See damping spring
Reset spring c	See brake spring
Lowering valve S	Valve to reduce the lowering speed
Lowering time	Time from switching the motor off until the bottom piston limit position is reached.

2 Safety

ELDRO® lifting thrusters are reliable electro-hydraulic machines for use in industrial systems. They are state of the art.

The generally applicable regulations and other binding directives regarding health and safety, accident prevention and environmental protection must be adhered to.

The following safety regulations must be adhered to before beginning any work on ELDRO® thrusters:

- Ensure that the industrial system is shut down
- De-energise the system
- Safeguard the system to prevent it being switched on again
- Test to ensure a de-energised state
- Cover or isolate adjacent live parts

2.1 Intended use

The ELDRO® thruster is partly completed machinery and must be connected to other parts to form a complete machine. The safety of this complete machine must prevent hazards caused by controlling and operating the system.

ELDRO® thrusters are used to apply straight work movements using electro-hydraulics. In drive technology, drives are braked or stopped using brakes with electro-hydraulic actuation thrusters (lifting thrusters). ELDRO® thrusters are mainly used in drive technology to bleed drum and disc brakes (brake bleeder).

However, ELDRO® thrusters can also be used in other areas of production, transport technology, warehousing and handling technology, wherever a straight work movement is required and a single drive is wanted. Applications as an actuator include actuating

- Valves
- Couplings
- Slides
- Throttle valves
- Locking thrusters

Intended use also includes adhering to the assembly, operating and maintenance procedures described in this assembly manual.

The technical data and the specifications for terminal assignments are specified on the type plate and in the manual, and must be adhered to.

ELDRO® thrusters may only be operated in the permissible installation position and operating mode. Only this intended use is permissible. Any other use is prohibited.

2.2 Unintended use

Reasonably foreseeable misuse

Any unintended use or impermissible operating modes constitutes misuse of the ELDRO® thrusters. For safety reasons, all applications not listed in the intended use section are strictly prohibited by the manufacturer.

All applications as an actuator always require confirmation from the manufacturer. Applications as actuators that cause the power supply for retracting the lifting rod to fail are not permitted due to the associated risk of accidents.

2.3 Staff qualifications

Qualified staff must be used for the ELDRO® thruster's intended use. The scope of responsibility, authority and supervision of personnel must be precisely stipulated by the operating company.

Qualified staff are people who, due to their training, experience and instruction, as well as their knowledge of applicable standards, regulations, accident prevention regulations and operating conditions, are authorised by the person responsible for system safety to perform the relevant required tasks and are thereby able to identify and avoid possible hazards.

Work on or with ELDRO® thrusters may only be performed by trained and qualified staff who have received system-specific instructions, who are authorised to do so and who have special knowledge and experience with the corresponding field.

Contact EMG Automation GmbH if the required staff qualifications are unclear.

2.3.1 Qualified personnel

ELDRO® thrusters may only be transported, set up, connected, operated and maintained by specialists. All work must be performed with the intended, intact tools, equipment, test equipment and consumables, and must be inspected by the specialists responsible. The specialists must be authorised to perform the required tasks by the person responsible for the industrial system's safety.

Specialists include industrial mechanics or people who have comparable, country-specific training and who have the following knowledge:

- Knowledge and experience in transporting, storing, assembling and disposing of the ELDRO® thrusters
- Knowledge and experience of the electrical, mechanical and hydraulic equipment on the components for the ELDRO® thrusters
- ELDRO® thruster functions
- Modifying the ELDRO® thrusters and re-adjusting them properly
- Hazards on the system and suitable safety measures

2.3.2 Qualified electrician

Electrical specialists include electricians who,

- due to their technical training, knowledge, and experience, as well as knowledge of applicable standards and regulations, are capable of carrying out work on electrical systems
- who have been commissioned and trained by the operating company to perform work on electrical systems and equipment on the ELDRO® thrusters.
- are familiar with the ELDRO® thruster functions
- can detect and avoid possible hazards by taking suitable safety measures.

2.3.3 Maintenance staff

Maintenance staff include industrial mechanics or people who have comparable, country-specific training. Maintenance staff are people who have been commissioned by the operating company to maintain the system and who have the following knowledge:

- Knowledge and experience of the electrical, mechanical and hydraulic equipment on the components for the ELDRO® thrusters
- ELDRO® thruster functions and maintenance points
- Hazards on the system and suitable safety measures
- Lubricating, cleaning, preserving, topping up to replacing consumables
- Replacing wear parts
- Modifying the ELDRO® thrusters and re-adjusting them properly

2.3.4 Responsible staff

The following table provides you with information on the staff qualifications that are the prerequisites for the corresponding tasks. Only people who have the corresponding qualification may perform these tasks.

Table 3: Responsible staff

Task	Responsible staff			Manufacturer or service partner authorised by the manufacturer
	Qualified personnel	Qualified electrician	Maintenance staff	
Transport	x			
Assembly	x			
Electrical installation		x		
Starting up	x			
Shutting down	x			
Fault rectification	x		x	x
Electrical fault rectification		x		x
Maintenance	x		x	
Repairs	x			x
Electrical repairs		x		x
Dismantling	x			
Storage	x			
Disposal	x			x

Contact EMG Automation GmbH if the required staff responsibilities are unclear.

2.4 Personal protective equipment

The operating company must prescribe personal protective equipment according to the danger risk.

Personal protective equipment includes the following among others:

- Safety shoes, work clothing, protective clothing if required
- Protective gloves
- Hard hat
- Safety goggles

This list of personal protective equipment is not exhaustive.

2.5 Electrical equipment

- Work on electrical equipment must be carried out exclusively by electricians.
- When performing any work on electrical components, the five safety rules must be adhered to:
 - Disconnect from the electrical supply
 - Safeguard to prevent a restart
 - Test to ensure a de-energised state
 - Earth and short-circuit
 - Cover or isolate adjacent live parts
- Perform regular checks for insulation and housing damage.
- Never operate the ELDRO® thruster with electrical connections that are faulty or not ready for operation.
- If there are power supply faults, the system must be switched off immediately.
- Before any work on electrical components, switch the mains disconnection thruster off and secure it to prevent it being switched on again.
- It is essential to observe the inspection and maintenance intervals specified by the manufacturer for electrical components.
- All touchable, conductive parts of the system are connected to the external earthing conductor system. The earthing conductor system must be inspected after performing maintenance work (e.g. replacing components).
- Some equipment (e.g. mains power units, servo controllers, converters) with electrical intermediate circuits may store residual voltage for a certain time after being disconnected. Before starting work on these systems, check that they are de-energised.

2.6 Process media

- The instructions on the manufacturer’s material safety data sheets must be followed.
- Contact with eyes or the skin should be avoided.
- Avoid inhaling vapours or mist.
- Soak up any spilled or leaking process media immediately with a binding agent and dispose of it properly.
- Keep containers with flammable substances and compressed, liquefied gases away from sources of heat.

2.7 Modifications

Changes, attachments and modifications to ELDRO® components, which could impair safety or functions may not be performed without written approval from the manufacturer.

2.8 Spare and wear parts

The use of spare and wear parts from third-party manufacturers may lead to risks. Only original parts or spare and wearing parts approved by the manufacturer may be used.



For information regarding replacement thrusters for ELDRO® types that can no longer be supplied, see the “Ordering notes for replacement thrusters” list.

3 Technical data

3.1 Type designation and type key



3 Technical data

3.1 Type designation and type key

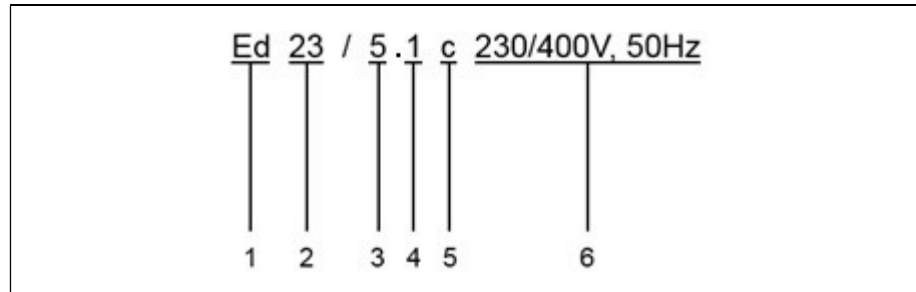

Figure 1: Type designation and type key

- 1 Ed: ELDRO®, three-phase version
Eg: ELDRO®, direct current version
- 2 Lifting force in daN
- 3 Lifting path in cm
- 4 Indicator for replacement and special thrusters
- 5 Letters for additional equipment:
 - c brake spring (c spring)
 - d damping spring (d spring)
 - H lifting valve
 - S lowering valve
- 6 Rated voltage / frequency

3.2 Specifications on the type plate

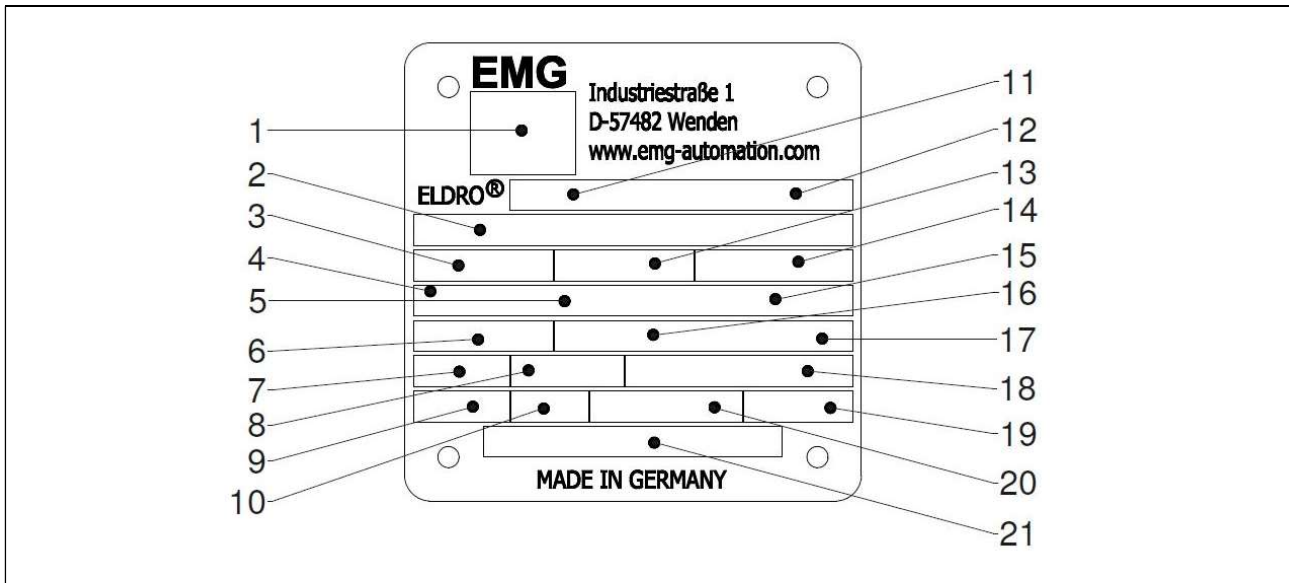

Figure 2: Type plate

- | | | | |
|----|-------------------------|----|------------------------------|
| 1 | Standard | 12 | Equipment |
| 2 | Serial number | 13 | Lifting path in mm |
| 3 | Lifting force in N | 14 | Year of construction |
| 4 | Operating mode | 15 | Switching processes per hour |
| 5 | Switch-on duration in % | 16 | Voltage |
| 6 | Switching type | 17 | Voltage tolerance |
| 7 | Frequency | 18 | Current consumption |
| 8 | Power consumption | 19 | Weight |
| 9 | ISO class | 20 | Operating fluid |
| 10 | Protection category | 21 | Temperature range |
| 11 | Thruster type | | |

3.3 Characteristics

Short lift thrusters

Table 4: Characteristics – short lift thrusters Ed 12/4-Ed 50/7

ELDRO® type	Ed							
	12/4	23/5 23/5.1 23/5.2 23/5.5	23/5 X01 25/5	30/5 30/5.1 30/5.2	30/5 X01	50/6 50/6.1 50/6.2 50/6.3 50/6.5	50/6 X01	50/7
Lifting force [N]	120	220	300	300	450	500	675	500
Lifting path [mm]	40	50	50	50	50	60	60	70
Brake spring force (c spring) ¹⁾ [N]	60	180	–	270	-	460	-	460
Power consumption [W]	120	165	165	200	200	210	260	210
Current consumption at 400 V ²⁾ [A]	0,36	0,5	0,5	0,5	0,5	0,5	0,5	0,5
Switching frequency at S3-60% ED ³⁾ [c/h]	2000	2000	2000	2000	1500	2000	2000	2000
Weight [kg]	8	11	11	14	14	21	21	21

Table 5: Characteristics – short lift thrusters Ed 80/6-Ed 125/7 X01

ELDRO® type	Ed							
	80/6 80/6.1 80/6.5	80/6 X01	80/6.6	80/7	80/7.6	121/6	125/6	125/7 125/7 X01
Lifting force [N]	800	1400	1100	800	1100	1250	1250	1250
Lifting path [mm]	60	60	60	70	70	60	60	70
Brake spring force (c spring) ¹⁾ [N]	750	-	–	–	–	1200	–	–
Power consumption [W]	330	330	310	330	310	330	330	330
Current consumption at 400 V ²⁾ [A]	1,2	1,2	0,66	1,2	0,66	1,2	1,1	1,1
Switching frequency at S3-60% ED ³⁾ [c/h]	2000	1500	2000	2000	2000	2000	2000	2000
Weight [kg]	22	22	22	22	22	39	22	22

Table 6: Characteristics – short lift thrusters Ed 185/6-Ed 400/7

ELDRO® type	Ed							
	185/6	201/6	201/7	201/8	301/6 301/6.1	301/7	400/6	400/7
Lifting force [N]	1850	2000	2000	2000	3000	3000	4000	4000
Lifting path [mm]	60	60	70	80	60	70	60	70
Brake spring force (c spring) ¹⁾ [N]	1900	1900	1900	1900	2700	2700	–	–
Power consumption [W]	450	450	450	450	550	550	550	550
Current consumption at 400 V ²⁾ [A]	1,3	1,3	1,3	1,3	1,4	1,4	1,3	1,3
Switching frequency at S3-60% ED ³⁾ [c/h]	2000	2000	2000	2000	1500	1500	600	600
Weight [kg]	39	39	39	39	39	39	39	39

Table 7: Characteristics – short lift thrusters Ed 400/8-Ed 630/9

ELDRO® type	Ed							
	400/8	400/8 X01	450/8	500/7	500/8	501/8	630/8	630/9
Lifting force [N]	4000	4500	4500	5000	5000	5000	6300	6300
Lifting path [mm]	80	80	80	70	80	80	80	90
Brake spring force (c spring) ¹⁾ [N]	–	–	–	–	–	–	–	–
Power consumption [W]	550	600	600	700	700	700	700	700
Current consumption at 400 V ²⁾ [A]	1,3	1,3	1,3	1,5	1,6	1,6	1,8	1,8
Switching frequency at S3-60% ED ³⁾ [c/h]	600	600	600	400	400	400	400	400
Weight [kg]	39	39	39	50	50	50	70	70

- 1) Brake force values apply at 1/3 of the nominal lifting path
- 2) Values for the piston's mechanical limit positions. The specified values increase during the lifting process. At a thruster working temperature of -25 °C, the current consumption is around 1.5 that of the current consumption at +20 °C.
- 3) Continuous operation S1 and intermittent operation S3 are permitted up to an ambient temperature of +50 °C



All technical data relates to a +20 °C thruster working temperature.

Long lift thrusters

Table 8: Characteristics – long lift thrusters Ed 50/12-Ed 301/12.5

ELDRO® type	Ed						
	50/12	80/12 80/12.1	121/12 121/12.1	121/20	185/16	201/12 201/12.1 201/12.5	301/12 301/12.1 301/12.5
Lifting force [N]	500	800	1250	1250	1850	2000	3000
Lifting path [mm]	120	120	120	200	160	120	150
Brake spring force (c spring) ¹⁾ [N]	–	–	–	–	–	–	–
Power consumption [W]	210	330	330	330	450	450	550
Current consumption at 400 V ²⁾ [A]	0,5	1,2	1,2	1,1	1,2	1,1	1,3
Switching frequency at S3-60% ED ³⁾ [c/h]	1200	1200	1200	400	400	1200	400
Weight [kg]	27	27	39	50	40	39	41

Table 9: Characteristics – long lift thrusters Ed 301/15-Ed 630/10

ELDRO® type	Ed						
	301/15	350/20 350/20.1 350/20.2 350/20 X01 350/20 X02	400/10	450/12	450/20	500/10	630/10
Lifting force [N]	3000	3500	4000	4500	4500	5000	6300
Lifting path [mm]	150	200	100	120	200	100	100
Brake spring force (c spring) ¹⁾ [N]	–	–	–	–	–	–	–
Power consumption [W]	550	550	550	600	400	900	700
Current consumption at 400 V ²⁾ [A]	1,3	1,1	1,3	1,3	1,1	2,0	1,8
Switching frequency at S3-60% ED ³⁾ [c/h]	400	400	600	600	600	400	400
Weight [kg]	50	50	39	40	50	50	70

- 1) Brake force values apply at 1/3 of the nominal lifting path
- 2) Values for the piston's mechanical limit positions. The specified values increase during the lifting process. At a thruster working temperature of -25 °C, the current consumption is around 1.5 that of the current consumption at +20 °C.
- 3) Continuous operation S1 and intermittent operation S3 are permitted up to an ambient temperature of +50 °C



All technical data relates to a +20 °C thruster working temperature.

3.4 Dimensions

3.4.1 Type Ed 12

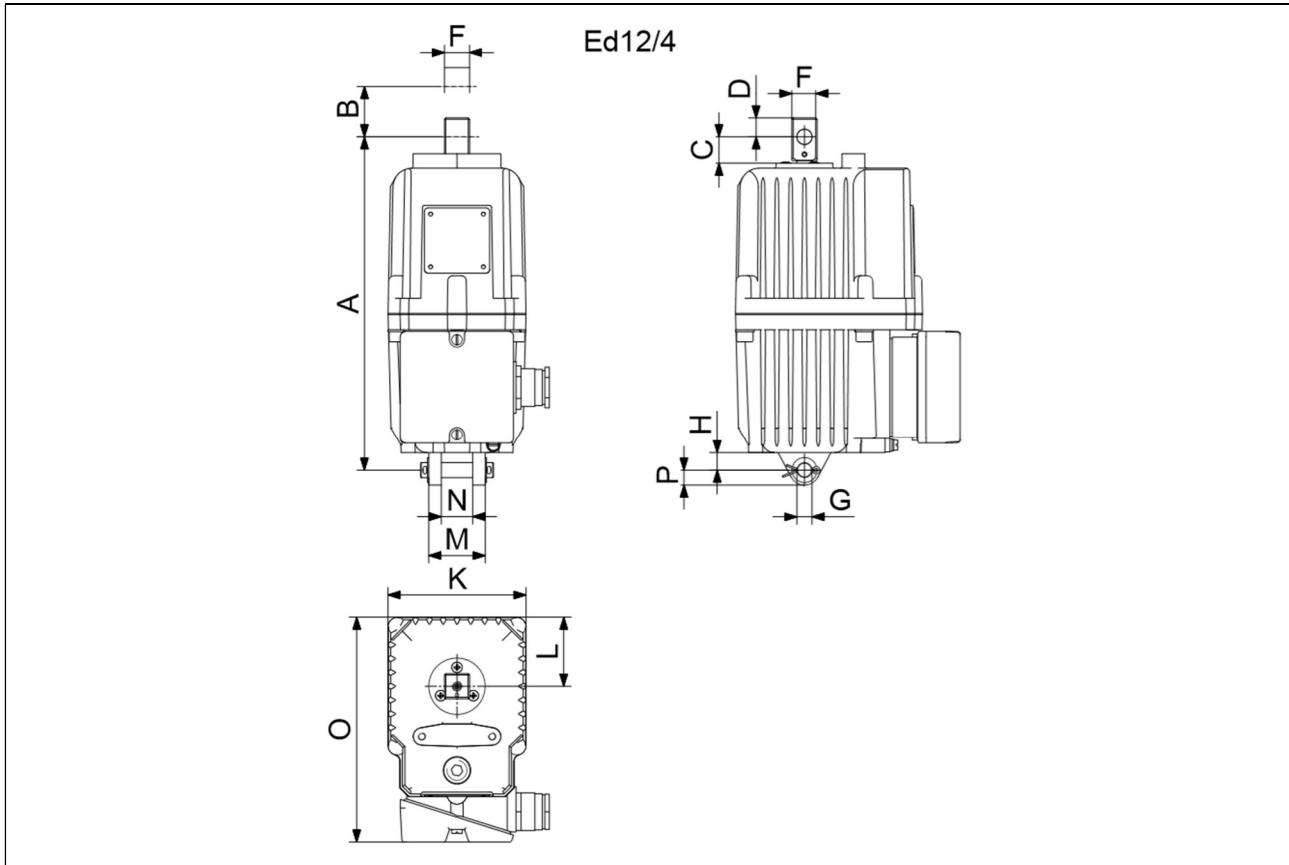

Figure 3: Example type Ed 12/4

Ed 12 dimensions

Table 10: Ed 12/4 dimensions

Type	A	B	C	D	E ¹⁾	E1 ¹⁾	F	G ²⁾	H	K	L	M	N	O
Ed 12/4	265	40	20	10	12	–	20	12	12	110	55	45	25	178

1) Tolerance +0.1

2) Tolerance +0.15 to +0.25

3 Technical data

3.4 Dimensions



3.4.2 Type Ed 23 to Ed 25

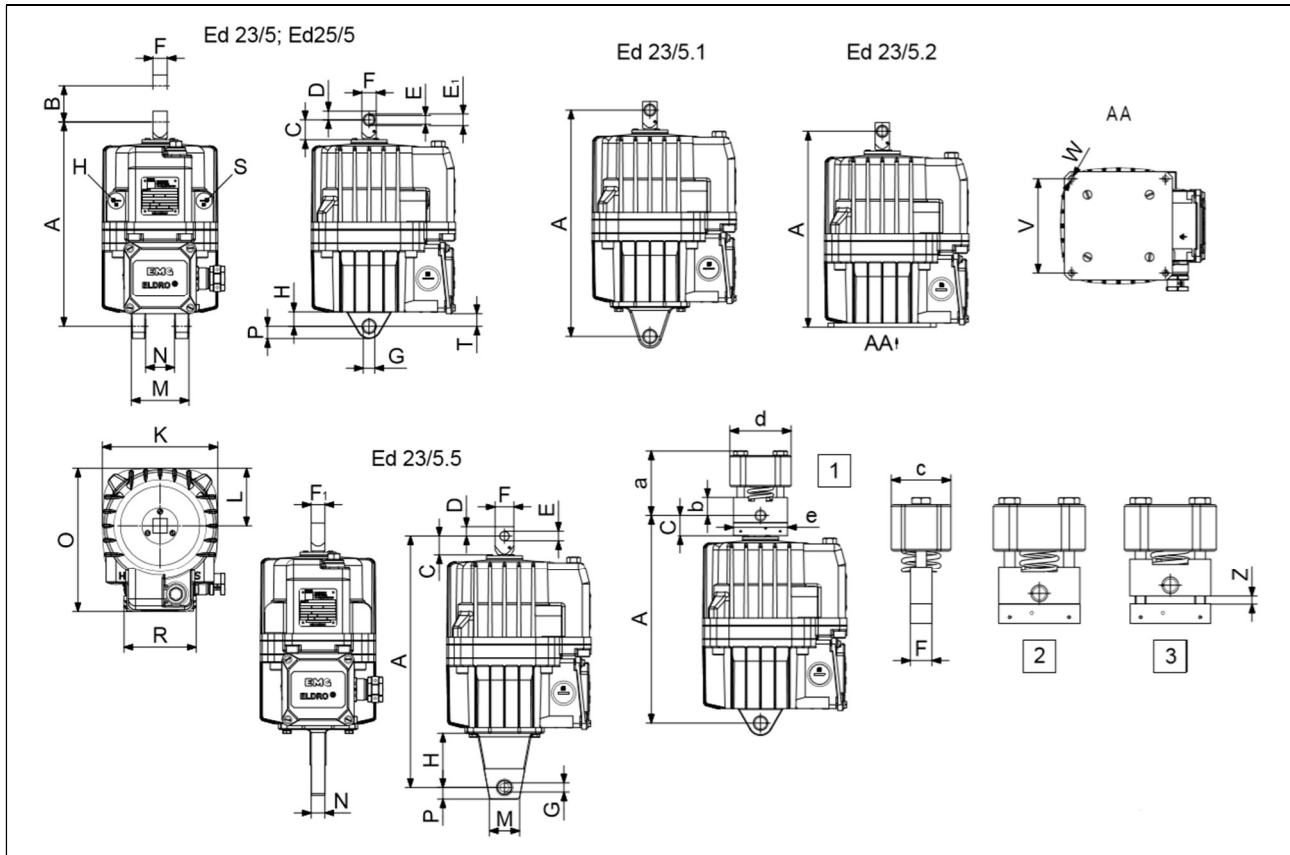

Figure 4: Dimensional drawing – example: Type Ed 23/5

- 1 d spring
- 2 released (thruster bled)
- 3 tensioned (thruster braked)

The foot attachment for Ed 23/5.1 and Ed 23/5.2 can be installed offset by 90° (not possible for thrusters with limit switches). The top thrust shackle is rotatable (not possible for thrusters with limit switches).

Ed 23 dimensions

Table 11: Ed 23 – 1 dimensions

Type	A	B	C	D	E ¹⁾	E1 ¹⁾	F	F1	G ²⁾	H	K	L	M
Ed 23/5	286	50	26	12	12	16	20	–	16	20	160	80	80
Ed 23/5.1	314	50	26	12	12	16	20	–	16	20	160	80	80
Ed 23/5.2	272	50	26	12	12	16	20	–	16	20	160	80	80
Ed 23/5.5	350	50	26	12	12.73	–	26	19	12.73	81	160	80	41
Ed 23/5 X01	286	50	26	12	12	16	20	–	16	20	160	80	80

Table 12: Ed 23 – 2 dimensions

Type	N	O	P	R	T	V	W	a	b	c	d	e	z	
Ed 23/5	40	200	16	92	18	–	–	100	20	55	85	75	15	
Ed 23/5.1	40	200	16	92	18	–	–	100	20	55	85	75	15	
Ed 23/5.2	40	200	16	92	18	130	9	100	20	55	85	75	15	
Ed 23/5.5	19	200	16	92	18	–	–	–	–	–	–	–	–	
Ed 23/5 X01	40	200	16	92	18	–	–	100	20	55	85	75	15	

1) Tolerance +0.1

2) Tolerance +0.15 to +0.25

(E can be converted to E1 by removing the clamping bush)

Ed 25 dimensions

Table 13: Ed 25 – 1 dimensions

Type	A	B	C	D	E ¹⁾	E1 ¹⁾	F	F1	G ²⁾	H	K	L	M
Ed 25/5	286	50	26	12	12	16	20	–	16	20	160	80	80

Table 14: Ed 25 – 2 dimensions

Type	N	O	P	R	T	V	W	a	b	c	d	e	z	
Ed 25/5	40	200	16	92	18	–	–	100	20	55	85	75	15	

1) Tolerance +0.1

2) Tolerance +0.15 to +0.25

(E can be converted to E1 by removing the clamping bush)

3 Technical data

3.4 Dimensions



3.4.3 Type Ed 30

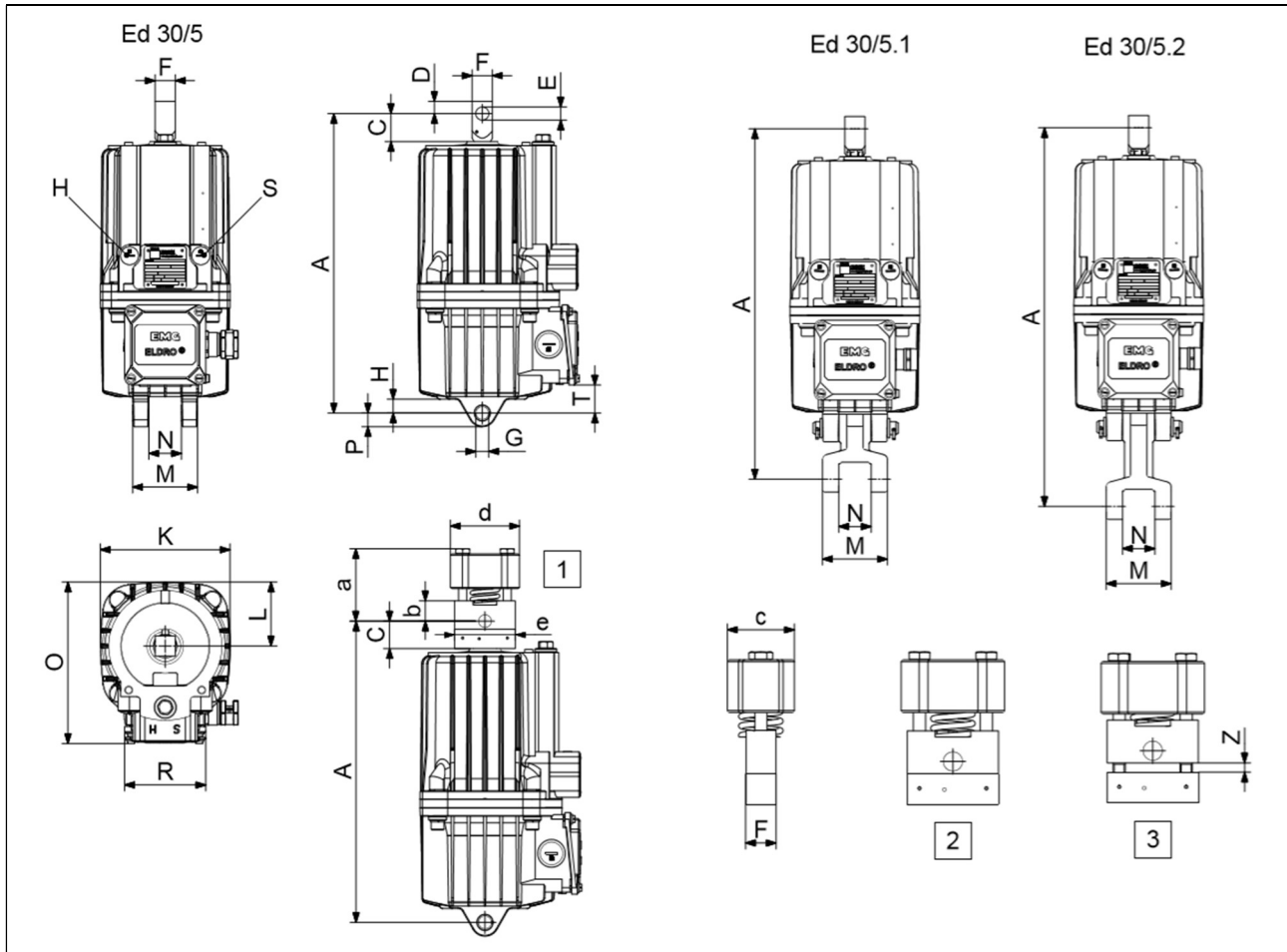

Figure 5: Dimensional drawing – example: Type Ed 30/5

- H Lifting valve
- S Lowering valve

- 1 d spring
- 2 released (thruster bled)
- 3 tensioned (thruster braked)

Ed 30 dimensions

Table 15: Ed 30 – 1 dimensions

Type	A	B	C	D	E ¹⁾	F	F1	G ²⁾	H	K	L	M	N
Ed 30/5	370	50	34	15	16	25	–	16	18	160	80	80	40
Ed30/5.1	433	50	34	15	16	30	25	16	18	160	80	80	40
Ed 30/5.2	468	50	34	15	16	30	25	16	116	160	80	80	40
Ed 30/5 X01	370	50	34	15	16	25	–	16	18	160	80	80	40

Table 16: Ed 30 – 2 dimensions

Type	O	R	T	a	b	c	d	e	z				
Ed 30/5	197	80	34	100	20	55	85	75	15				
Ed 30/5.1	197	80	97	100	20	55	85	75	15				
Ed 30/5.2	197	80	132	100	20	55	85	75	15				
Ed 30/5 X01	197	80	34	100	20	55	85	75	15				

1) Tolerance +0.1

2) Tolerance +0.15 to +0.25

3 Technical data

3.4 Dimensions



3.4.4 Types Ed 50, Ed 80, Ed 125

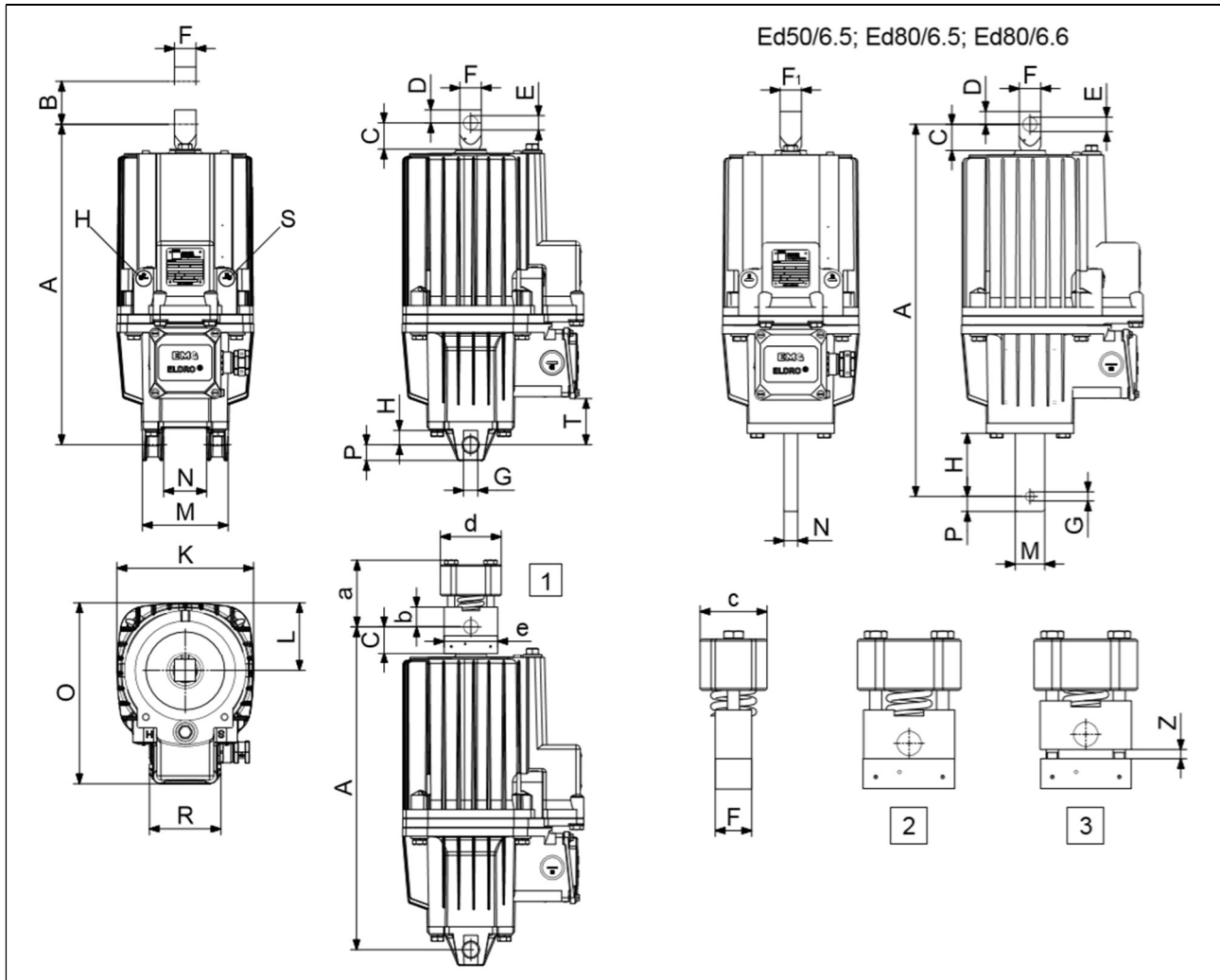

Figure 6: Dimensional drawing – example: Type Ed 50/6; Ed 80/6.5; Ed 80/6.6

- 1 d spring
- 2 released (thruster bled)
- 3 tensioned (thruster braked)

Ed 50 dimensions – short lift thrusters

Table 17: Ed 50 – 1 dimensions

Type	A	B	C	D	E ¹⁾	F	F1	G ²⁾	H	K	L	M	N
Ed 50/6	435	60	36	18	20	30	–	20	23	195	97	120	60
Ed 50/6 X01	435	60	36	18	20	30	–	20	23	195	97	120	60
Ed 50/6.1	511	60	36	18	16	30	25	24	76	195	97	120	60
Ed 50/6.2	435	60	36	18	16	30	25	16	23	195	97	120	60
Ed 50/6.3	468	60	69.5	18	16	30	25	16	23	195	97	120	60
Ed 50/6.5	445	60	36	14	19.13	29	22	19.13	27	195	97	41	25
Ed 50/7	435	70	36	18	20	30	–	20	23	195	97	120	60

Table 18: Ed 50 – 2 dimensions

Type	O	R	T	a	b	c	d	e	z				
Ed 50/6	254	90	52	100	20	55	85	55	15				
Ed 50/6 X01	254	90	52	100	20	55	85	55	15				
Ed 50/6.1	254	90	105	100	20	55	85	55	15				
Ed 50/6.2	254	90	52	100	20	55	85	55	15				
Ed 50/6.3	254	90	52	100	20	55	85	55	15				
Ed 50/6.5	254	90	62	–	–	–	–	–	–				
Ed 50/7	254	90	52	100	20	55	85	55	15				

1) Tolerance +0.1

2) Tolerance +0.15 to +0.25

Ed 80 dimensions – short lift thrusters

Table 19: Ed 80 – 1 dimensions

Type	A	B	C	D	E ¹⁾	F	F1	G ²⁾	H	K	L	M	N
Ed 80/6	450	60	36	18	20	30	–	20	23	195	97	120	60
Ed 80/6 X01	450	60	36	18	20	30	–	20	23	195	97	120	60
Ed 80/6.1	509	60	36	18	16	30	25	24	76	195	97	120	60
Ed 80/6.5	508	60	36	16	22.3	30	25	22.3	38	195	97	48	32
Ed 80/6.6	508	60	36	16	22.3	30	25	22.3	38	195	97	48	32
Ed 80/7	450	70	36	18	20	30	–	20	23	195	97	120	60

Table 20: Ed 80 – 2 dimensions

Type	O	R	T	a	b	c	d	e	z				
Ed 80/6	254	90	67	100	20	55	85	55	15				
Ed 80/6 X01	254	90	67	100	20	55	85	55	15				
Ed 80/6.1	254	90	105	100	20	55	85	55	15				
Ed 80/6.5	254	90	110	–	–	–	–	–	–				
Ed 80/6.6	254	90	110	–	–	–	–	–	–				
Ed 80/7	254	90	67	100	20	55	85	55	15				

1) Tolerance +0.1

2) Tolerance +0.15 to +0.25

Ed 125 dimensions – short lift thrusters

Table 21: Ed 125 – 1 dimensions

Type	A	B	C	D	E ¹⁾	F	F1	G ²⁾	H	K	L	M	N
Ed 125/6	450	60	36	18	20	30	–	20	23	195	97	120	60
Ed 125/7	450	70	36	18	20	30	–	20	23	195	97	120	60
Ed 125/7 X01	450	70	36	16	20	30	–	20	23	195	97	120	60

Table 22: Ed 125 – 2 dimensions

Type	O	R	T	a	b	c	d	e	z				
Ed 125/6	254	90	67	100	20	55	85	55	15				
Ed 125/7	254	90	67	100	20	55	85	55	15				
Ed 125/7 X01	254	90	67	100	20	55	85	55	15				

1) Tolerance +0.1

2) Tolerance +0.15 to +0.25

Ed 50, Ed 80 dimensions – long lift thrusters

Table 23: Ed 50, Ed 80 – 1 dimensions

Type	A	B	C	D	E ¹⁾	F	F1	G ²⁾	H	K	L	M	N
Ed 50/12	515	120	36	18	20	30	–	20	23	195	97	120	60
Ed 80/12	530	120	36	18	20	30	–	20	23	195	97	120	60
Ed 80/12.1	606	120	36	16	20	30	25	24	26	195	97	120	60

Table 24: Ed 50, Ed 80 – 2 dimensions

Type	O	R	T										
Ed 50/12	254	90	52										
Ed 80/12	254	90	67										
Ed 80/12.1	254	90	67										

1) Tolerance +0.1

2) Tolerance +0.15 to +0.25

3 Technical data

3.4 Dimensions



3.4.5 Types Ed 121 to Ed 501

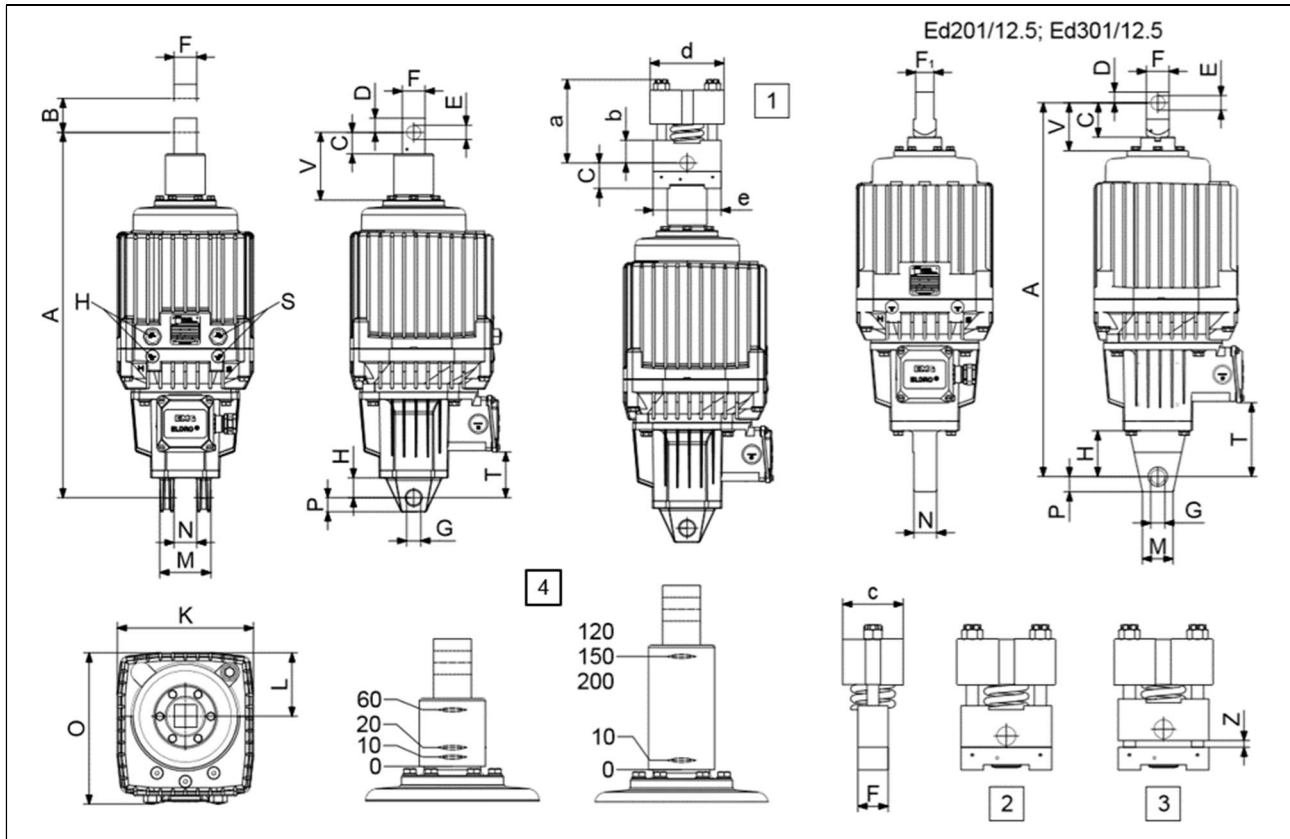

Figure 7: Dimensional drawing – example: Type Ed 201/12.5; Ed 301/12.5

- | | | | |
|---|----------------|---|-----------------------------|
| H | Lifting valve | 2 | released (thruster bled) |
| S | Lowering valve | 3 | tensioned (thruster braked) |
| 1 | d spring | 4 | Lift markings |



Markings are applied to the piston guide bushing for easier brake adjustment or inspection. They can be read from the bottom edge of the piston rod protection pipe (see drawing PCA-0027-00-005 in the appendix).

Ed 121 dimensions – short lift thrusters

Table 25: Ed 121 – 1 dimensions

Type	A	B	C	D	E ¹⁾	F	G ²⁾	H	K	L	M	N
Ed 121/6	645	60	38	25	25	40	25	35	240	112	90	40

Table 26: Ed 121 – 2 dimensions

Type	O	T	V	a	b	c	d	e	z				
Ed 121/6	260	77	119.5	147	35	80	130	120	20				

1) Tolerance +0.1

2) Tolerance +0.15 to +0.20

Ed 185 dimensions – short lift thrusters

Table 27: Ed 185 – 1 dimensions

Type	A	B	C	D	E ¹⁾	F	G ²⁾	H	K	L	M	N
Ed 185/6	600	60	42	25	25	40	27	44	240	112	160	80

Table 28: Ed 185 – 2 dimensions

Type	O	T	V	a	b	c	d	e	z				
Ed 185/6	260	87	67	147	35	80	130	120	20				

1) Tolerance +0.1

2) Tolerance +0.15 to +0.20

Ed 201 dimensions – short lift thrusters

Table 29: Ed 201 – 1 dimensions

Type	A	B	C	D	E ¹⁾	F	G ²⁾	H	K	L	M	N
Ed 201/6	645	60	38	25	25	40	25	35	240	112	90	40
Ed 201/7	705	70	38	25	25	40	25	35	240	112	90	40
Ed 201/8	645	80	38	25	25	40	25	35	240	112	90	40

Table 30: Ed 201 – 2 dimensions

Type	O	T	V	a	b	c	d	e	z				
Ed 201/6	260	77	119.5	147	35	80	130	120	20				
Ed 201/7	260	77	119.5	147	35	80	130	120	20				
Ed 201/8	260	77	119.5	147	35	80	130	120	20				

1) Tolerance +0.1

2) Tolerance +0.15 to +0.20

3 Technical data

3.4 Dimensions



Ed 301 dimensions – short lift thrusters

Table 31: Ed 301 – 1 dimensions

Type	A	B	C	D	E ¹⁾	F	G ²⁾	H	K	L	M	N
Ed 301/6	645	38	38	25	25	40	25	35	240	112	90	40
Ed 301/6.1	680	60	38	25	25	40	25	70	240	112	90	40
Ed 301/7	705	70	38	25	25	40	25	35	240	112	90	40

Table 32: Ed 301 – 2 dimensions

Type	O	T	V	a	b	c	d	e	z				
Ed 301/6	260	77	119.5	147	35	80	130	120	20				
Ed 301/6.1	260	112	119.5	147	35	80	130	120	20				
Ed 301/7	260	77	119.5	147	35	80	130	120	20				

1) Tolerance +0.1

2) Tolerance +0.15 to +0.20

Ed 400 dimensions – short lift thrusters

Table 33: Ed 400 – 1 dimensions

Type	A	B	C	D	E ¹⁾	F	G ²⁾	H	K	L	M	N
Ed 400/6	645	60	42	25	25	40	25	35	240	112	90	40
Ed 400/7	705	80	42	25	25	40	25	35	240	112	90	40
Ed 400/8	645 705	80	42	25	25	40	25	35	240	112	90	40
Ed 400/8 X01	645	80	42	25	25	40	25	35	240	112	90	40

Table 34: Ed 400 – 2 dimensions

Type	O	T	V	a	b	c	d	e	z				
Ed 400/6	265	77	119	-	-	-	-	-	-				
Ed 400/7	265	77	179	-	-	-	-	-	-				
Ed 400/8	265	77	179	-	-	-	-	-	-				
Ed 400/8 X01	265	77	179	-	-	-	-	-	-				

1) Tolerance +0.1

2) Tolerance +0.15 to +0.20

Ed 450 dimensions – short lift thrusters

Table 35: Ed 450 – 1 dimensions

Type	A	B	C	D	E ¹⁾	F	G ²⁾	H	K	L	M	N
Ed 450/8	645	80	42	25	25	40	25	35	240	112	90	40

Table 36: Ed 450 – 2 dimensions

Type	O	T	V	a	b	c	d	e	z				
Ed 450/8	265	77	179	–	–	–	–	–	–				

1) Tolerance +0.1

2) Tolerance +0.15 to +0.20

Ed 500 dimensions – short lift thrusters

Table 37: Ed 500 – 1 dimensions

Type	A	B	C	D	E ¹⁾	F	G ²⁾	H	K	L	M	N
Ed 500/7	705	70	42	25	25	40	25	35	250	117	90	40
Ed 500/8	705	80	42	25	25	40	25	35	250	117	90	40

Table 38: Ed 500 – 2 dimensions

Type	O	T	V	a	b	c	d	e	z				
Ed 500/7	265	77	99.5	–	–	–	–	–	–				
Ed 500/8	265	77	99.5	–	–	–	–	–	–				

1) Tolerance +0.1

2) Tolerance +0.15 to +0.20

Ed 501 dimensions – short lift thrusters

Table 39: Ed 501 – 1 dimensions

Type	A	B	C	D	E ¹⁾	F	G ²⁾	H	K	L	M	N
Ed 501/8	665	80	52.5	25	25	40	25	35	250	117	90	40

Table 40: Ed 501 – 2 dimensions

Type	O	T	V	a	b	c	d	e	z				
Ed 501/8	265	77	59.5	–	–	–	–	–	–				

1) Tolerance +0.1

2) Tolerance +0.15 to +0.20

3 Technical data

3.4 Dimensions



Ed 121 dimensions – long lift thrusters

Table 41: Ed 121 – 1 dimensions

Type	A	B	C	D	E ¹⁾	F	F1	G ²⁾	H	K	L	M	N
Ed 121/12	705	120	38	25	25	40	–	25	35	240	112	90	40
Ed 121/12.1	765	120	38	25	25	40	–	25	95	240	112	90	40
Ed 121/20	880	200	38	25	25	40	–	27	44	250	117	160	80

Table 42: Ed 121 – 2 dimensions

Type	O	T	V										
Ed 121/12	260	77	179.5										
Ed 121/12.1	260	137	179.5										
Ed 121/20	265	77	266										

1) Tolerance +0.1

2) Tolerance +0.15 to +0.25

Ed 185 dimensions – long lift thrusters

Table 43: Ed 185 – 1 dimensions

Type	A	B	C	D	E ¹⁾	F	F1	G ²⁾	H	K	L	M	N
Ed 185/16	700	155	38	25	25	40	–	27	35	240	112	90	40

Table 44: Ed 185 – 2 dimensions

Type	O	T	V										
Ed 185/16	260	77	165.5										

1) Tolerance +0.1

2) Tolerance +0.15 to +0.25

Ed 201 dimensions – long lift thrusters

Table 45: Ed 201 – 1 dimensions

Type	A	B	C	D	E ¹⁾	F	F1	G ²⁾	H	K	L	M	N
Ed 201/12	705	120	38	25	25	40	–	25	35	240	112	90	40
Ed 201/12.1	765	120	38	25	25	40	–	25	95	240	112	90	40
Ed 201/12.5	660	120	29	19	25.4	40	32	25.4	130	240	112	54	38

Table 46: Ed 201 – 2 dimensions

Type	O	T	V										
Ed 201/12	260	77	179.5										
Ed 201/12.1	260	137	179.5										
Ed 201/12.5	260	130	84.5										

1) Tolerance +0.1

2) Tolerance +0.15 to +0.25

Ed 301 dimensions – long lift thrusters

Table 47: Ed 301 – 1 dimensions

Type	A	B	C	D	E ¹⁾	F	F1	G ²⁾	H	K	L	M	N
Ed 301/12	705	120	38	25	25	40	–	25	35	240	112	90	40
Ed 301/12.1	800	120	38	25	25	40	–	25	95	240	112	90	40
Ed 301/12.5	660	120	29	19	25.4	40	32	25.4	130	240	112	54	38
Ed 301/15	880	150	38	25	25	40	–	27	44	250	117	160	80

Table 48: Ed 301 – 2 dimensions

Type	O	T	V										
Ed 301/12	260	77	179.5										
Ed 301/12.1	260	172	179.5										
Ed 301/12.5	260	130	84.5										
Ed 301/15	265	87	266										

1) Tolerance +0.1

2) Tolerance +0.15 to +0.25

3 Technical data

3.4 Dimensions



Ed 400 dimensions – long lift thrusters

Table 49: Ed 400 – 1 dimensions

Type	A	B	C	D	E ¹⁾	F	F1	G ²⁾	H	K	L	M	N
Ed 400/10	645	100	38	25	25	40	–	25	35	240	112	90	40

Table 50: Ed 400 – 2 dimensions

Type	O	T	V										
Ed 400/10	265	77	119.2										

1) Tolerance +0.1

2) Tolerance +0.15 to +0.25

Ed 450 dimensions – long lift thrusters

Table 51: Ed 450 – 1 dimensions

Type	A	B	C	D	E ¹⁾	F	F1	G ²⁾	H	K	L	M	N
Ed 450/12	705	120	38	25	25	40	–	25	35	240	112	90	40
Ed 450/20	880	200	38	25	25	40	–	27	44	250	117	160	80

Table 52: Ed 450 – 2 dimensions

Type	O	T	V										
Ed 450/12	260	77	179.5										
Ed 450/20	265	87	266										

1) Tolerance +0.1

2) Tolerance +0.15 to +0.25

3.4.6 Type Ed 350
Ed 350/20, Ed 350/20-X01, Ed 350/20.2 dimensions

Figure 8: Dimensional drawing – example: Ed 350/20, Ed 350/20-X01, Ed 350/20.2

Table 53: Ed 350 – 1 dimensions

Type	A	B	C	D	E ¹⁾	F	G ²⁾	H	K	L	M	N	O
Ed 350/20	880	200	38	25	25	40	27	35	250	117	160	80	265
Ed 350/20 X01	880	200	38	25	25	40	27	44	250	117	160	80	265
Ed 350/20.2	1092	200	38	25	22.3	40	38.15	244	250	117	80	75	265

Table 54: Ed 350 – 2 dimensions

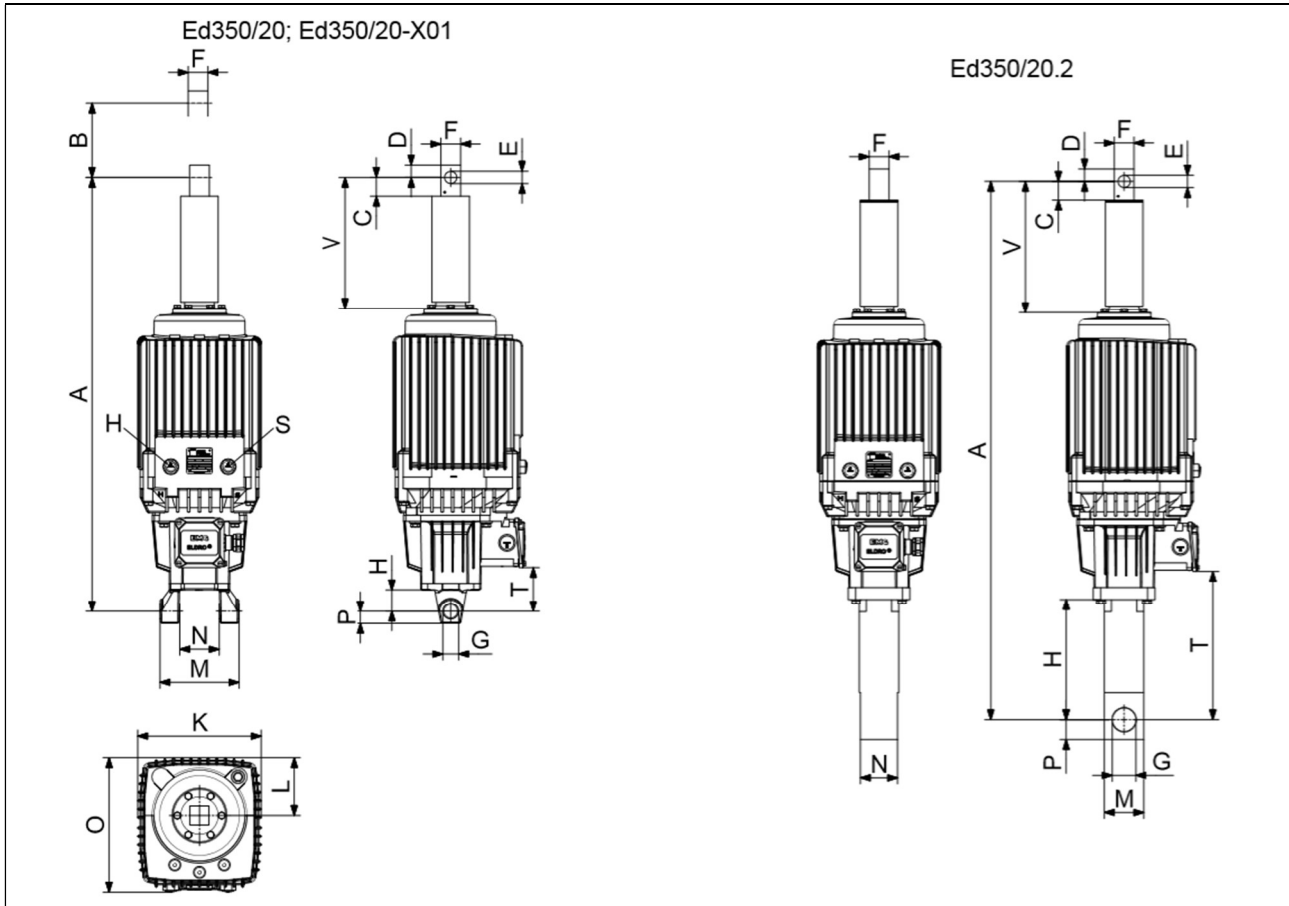
Type	P	T	U	V	W								
Ed 350/20	25	77	–	266	–								
Ed 350/20 X01	25	87	–	266	–								
Ed 350/20.2	40	307	–	266	–								

1) Tolerance +0.1

2) Tolerance +0.15 to +0.25

3 Technical data

3.4 Dimensions



Ed 350/20.1, Ed 350/20-X02 dimensions

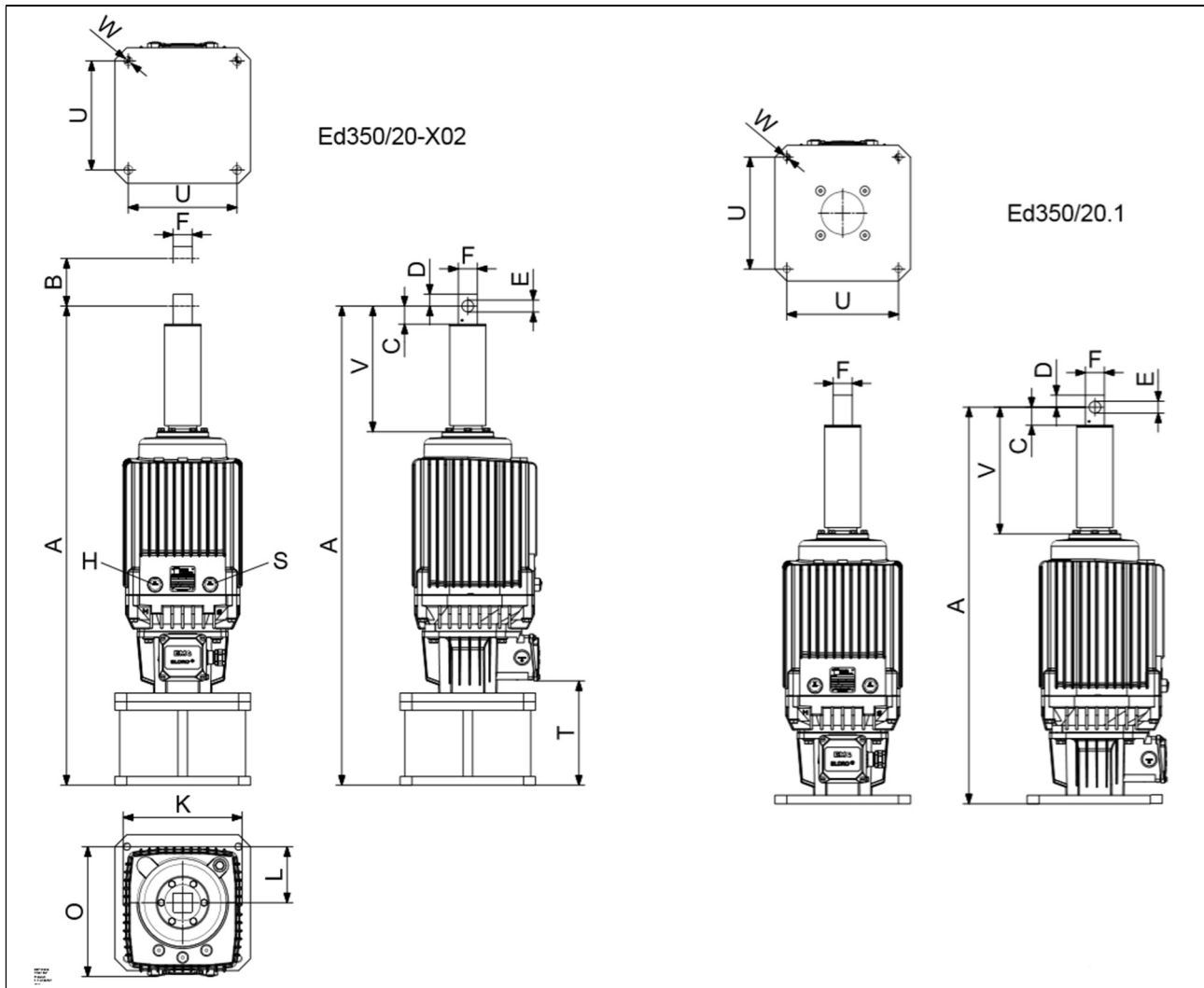

Figure 9: Dimensional drawing – example: Ed 350/20.1, Ed 350/20-X02

Table 55: Ed 350 – 1 dimensions

Type	A	B	C	D	E ¹⁾	F	G ²⁾	H	K	L	M
Ed 350/20.1	841	200	38	25	25	40	–	–	250	117	–
Ed 350/20 X02	1025.53	200	38	25	25.48	40	–	–	250	117	–

Table 56: Ed 350 – 2 dimensions

Type	N	O	P	T	U	V	W				
Ed 350/20.1	–	265	–	–	235	266	15				
Ed 350/20 X02	–	265	–	–	235	266	15				

1) Tolerance +0.1

2) Tolerance +0.15 to +0.25

3.4.7 Type Ed 630

Figure 10: Dimensional drawing – example: Ed 630/8, Ed 630/9, Ed 630/10

Ed 630 dimensions

Table 57: Ed 630 – 1 dimensions

Type	A	B	C	D	E ¹⁾	F	G ²⁾	H	K	L	M	N	O
Ed 630/8	705	80	38	25	25	40	25	34	274	127	90	40	328
Ed 630/9	705	90	38	25	25	40	25	34	274	127	90	40	328
Ed 630/10	705	100	38	25	25	40	25	34	274	127	90	40	328

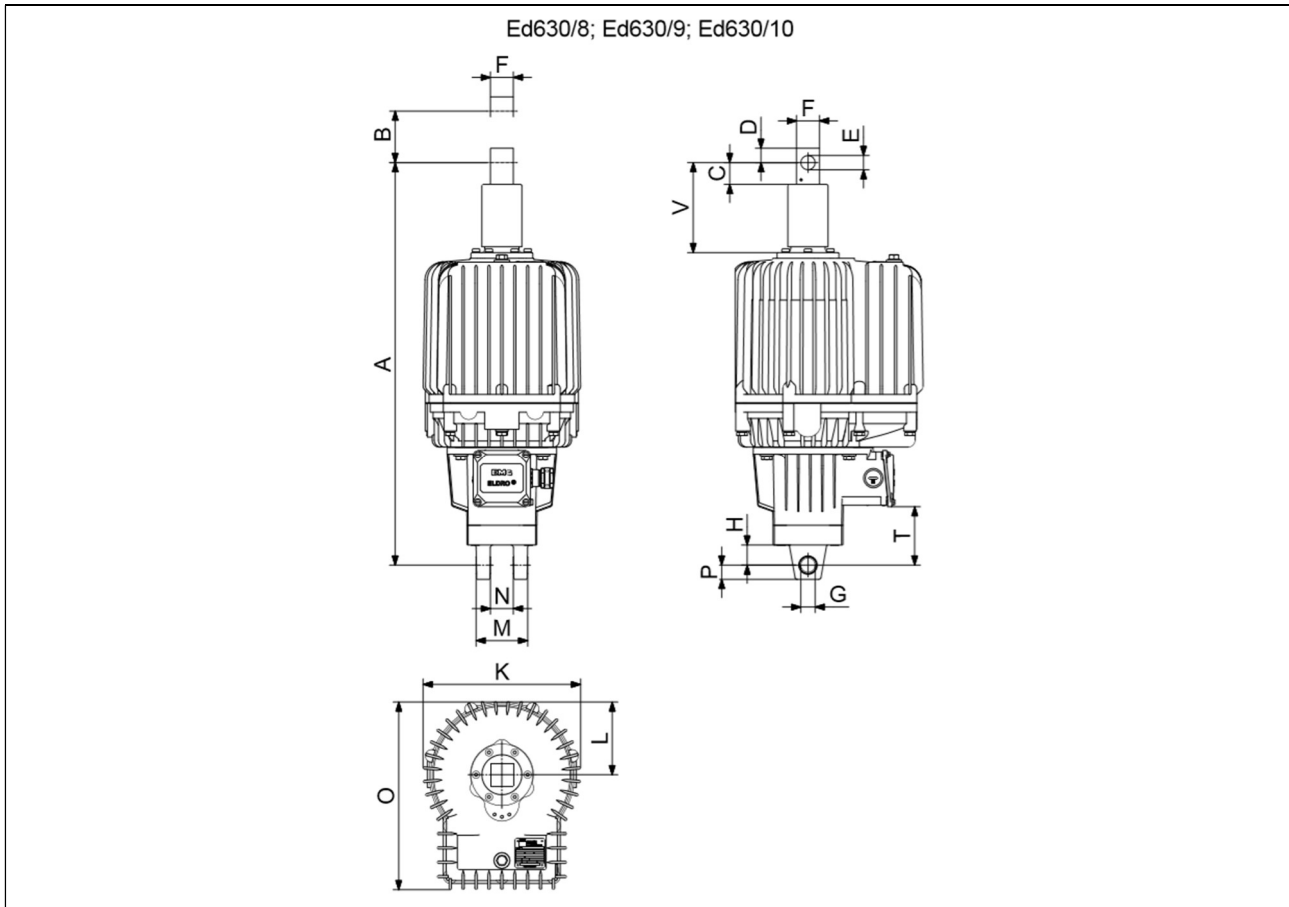
Table 58: Ed 630 – 2 dimensions

Type	P	T	V										
Ed 630/8	25	102	157										
Ed 630/9	25	102	157										
Ed 630/10	25	102	157										

1) Tolerance +0.1

2) Tolerance +0.15 to +0.25

3.5 Airborne sound emissions

The A-rated emission sound pressure level for all ELDRO® thrusters is 55 dB (A). This value was determined using an integrated sound pressure level measuring unit in accordance with DIN 45633 under the following measurement conditions:

- The ELDRO® thruster (measurement object) ran continuously.
- The measurement object was on a table around 0.8 m above the ground
- The measurement microphone was 1.6 m above the ground.
- The diagonal gap between the measurement microphone and the measurement object was 1 m.

3.6 Operating conditions

3.6.1 Ambient temperature

Deviations from the values specified in the following must be compensated for by suitable equipment and/or measures such as cooling units, heating, encapsulation, etc.

Table 59: Operating behaviour depending on the ambient temperature

Temperature range	Operating fluid	Technical statement
Standard range -25 °C +50 °C	HL	The lifting times may extend by up to four times on cold thrusters. The lowering times remain unchanged.
Special range above 50 °C	Special operating fluid	The manufacturer must be contacted
Special range below - 25 °C	HL	Only permissible when installed upright. Additional heating equipment (connection voltage 230 or 115 V) and the manufacturer must be contacted. The heating is connected in the junction box to a 9-pin terminal board via an additional M25x1.5 cable insert. The user must provide a temperature control thruster to control it. This must switch the heating on once the ambient temperature falls below -20 °C. The heating must not be switched on above +20 °C due to the risk of overheating.
Special range -35 °C to +40 °C	Special cold-resistant operating fluid	Heating not required

3.6.2 Air humidity

Up to 100 % air humidity is permitted if special measures are taken.

3.6.3 Aggressive ambient conditions

Special measures (special paint) are required for use in aggressive ambient conditions (e.g. salty ambient air).

3.6.4 Voltage and frequency tolerances

The permissible voltage tolerances in operation are $\pm 10\%$ at the measured power and measured frequency unless otherwise specified on the type plate.

The permissible frequency tolerance is $\pm 2\%$.

3.6.5 Installation height

The maximum permissible installation height is 1,000 m above sea level unless otherwise specified on the type plate.

4 Functional description

The ELDRO® electro-hydraulic lifting thrusters are manufactured as different types. These individual types can be merged into the following type groups due to their common attributes.

Table 60: Type groups

Type group	ELDRO® type
0	Ed 12/4
1	Ed 23/5, Ed 23/5.1, Ed 23/5.2, Ed 23/5.5
	Ed 25/5
2	Ed 30/5, Ed 30/5.1, Ed 30/5.2, Ed 30/5 X01
3	Ed 50/6, Ed 50/6 X01 Ed 50/6.1, Ed 50/6.2, Ed 50/6.3, Ed 50/6.5 Ed 50/7, Ed 50/12
	Ed 80/6, Ed 80/6 X01, Ed 80/6.1, Ed 80/6.5, Ed 80/6.6 Ed 80/7, Ed 80/7.6 Ed 80/12, Ed 80/12.1
	Ed 125/6, Ed 125/7, Ed 125/7 X01
4	Ed 121/6, Ed 121/12, Ed 121/12.1, Ed 121/20
	Ed 185/6, Ed 185/16
	Ed 201/6, Ed 201/7, Ed 201/8, Ed 201/12, Ed 201/12.1 Ed 201/12.5
	Ed 301/6, Ed 301/6.1, Ed 301/7, Ed 301/12, Ed 301/12.1 Ed 301/12.5, Ed 301/15
	Ed 350/20, Ed 350/20.1, Ed 350/20 X01, Ed 350/20.2, Ed 350/20 X02
	Ed 400/6, Ed 400/7, Ed 400/8, Ed 400/8 X01, Ed 400/10
	Ed 450/8, Ed 450/12, Ed 450/20
	Ed 500/7, Ed 500/8
Ed 501/8	
5	Ed 630/8, Ed 630/9, Ed 630/10

4.1 Mechanical layout

The ELDRO® thruster combines all structural elements of a complete hydraulic system in one structural unit. This comprises a three-phase asynchronous motor (direct current motor in the special version), a closed hydraulic system and the work cylinder with piston and lifting rod. The hydraulic system's operating fluid is used to generate the force.

4.1.1 Type group 1

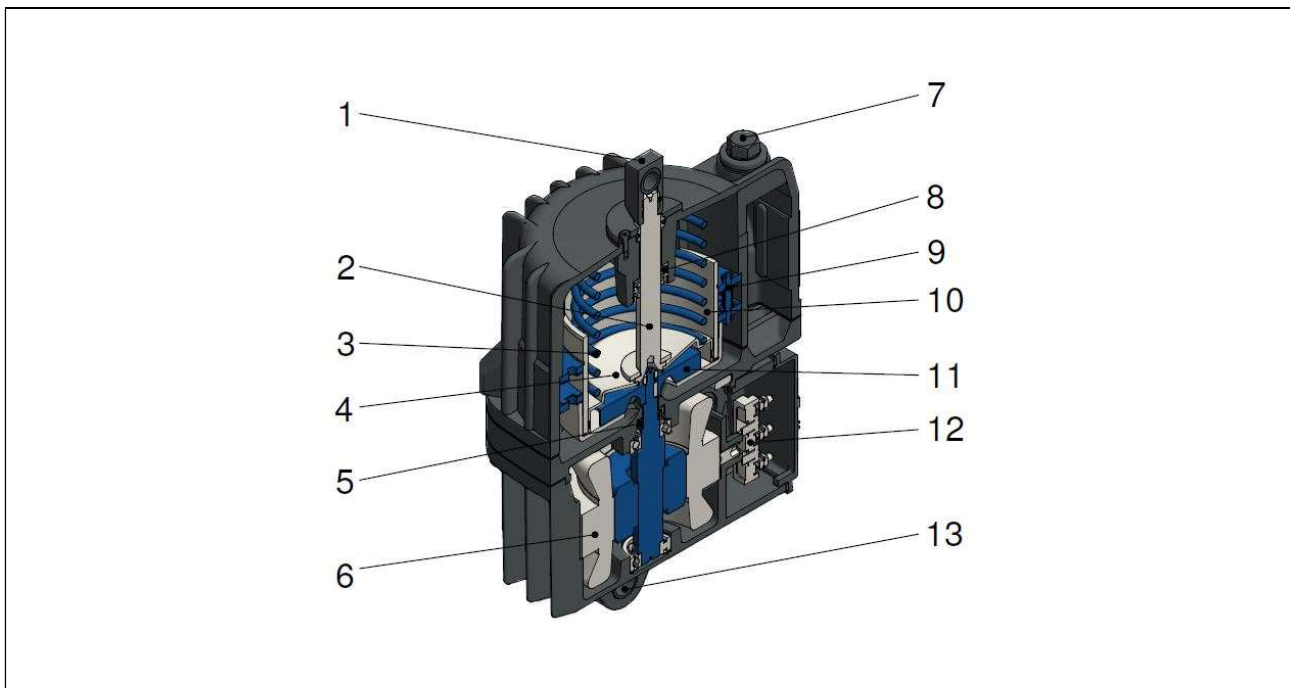

Figure 11: ELDRO® thruster layout (example: Ed 23/5 C-HS)

1	Thrust shackle	8	Double seal to the hydraulic space
2	Piston rod	9	Lifting/lowering valve
3	Brake spring (c spring)	10	Hydraulic cylinder
4	Piston	11	Hydraulic pump
5	Motor shaft seal	12	Junction box
6	Two-pole three-phase asynchronous motor	13	Foot attachment
7	Oil filling opening		

4 Functional description

4.1 Mechanical layout



4.1.2 Type group 3

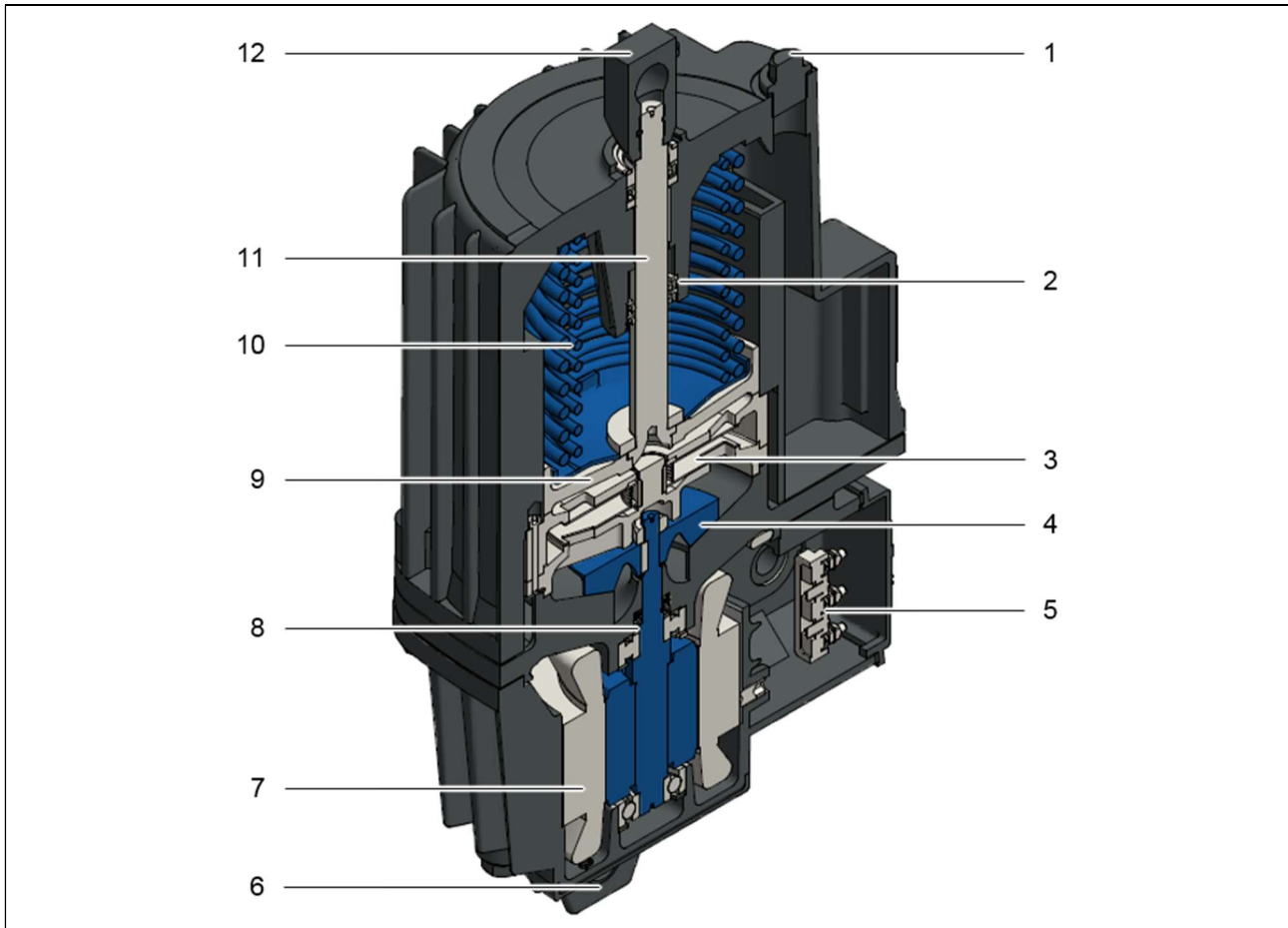

Figure 12: ELDRO® thruster layout (example: Ed 50 – Ed 80 C-HS)

- | | | | |
|---|------------------------------------|----|---|
| 1 | Oil filling opening | 7 | Two-pole three-phase asynchronous motor |
| 2 | Double seal to the hydraulic space | 8 | Motor shaft seal |
| 3 | Lifting/lowering valve | 9 | Piston |
| 4 | Hydraulic pump | 10 | Brake spring (c spring) |
| 5 | Junction box | 11 | Piston rod |
| 6 | Foot attachment | 12 | Thrust shackle |

4.1.3 Type group 4

Figure 13: ELDRO® thruster layout (example: Ed 121 – Ed 301 C-HS)

- | | | | |
|---|------------------------------------|----|---|
| 1 | Piston rod | 8 | Two-pole three-phase asynchronous motor |
| 2 | Double seal to the hydraulic space | 9 | Double motor shaft seal |
| 3 | Hydraulic cylinder | 10 | Piston |
| 4 | Lifting/lowering valve | 11 | Brake spring (c spring) |
| 5 | Hydraulic pump | 12 | Oil filling opening |
| 6 | Junction box | 13 | Thrust shackle |
| 7 | Foot attachment | | |

4 Functional description

4.1 Mechanical layout

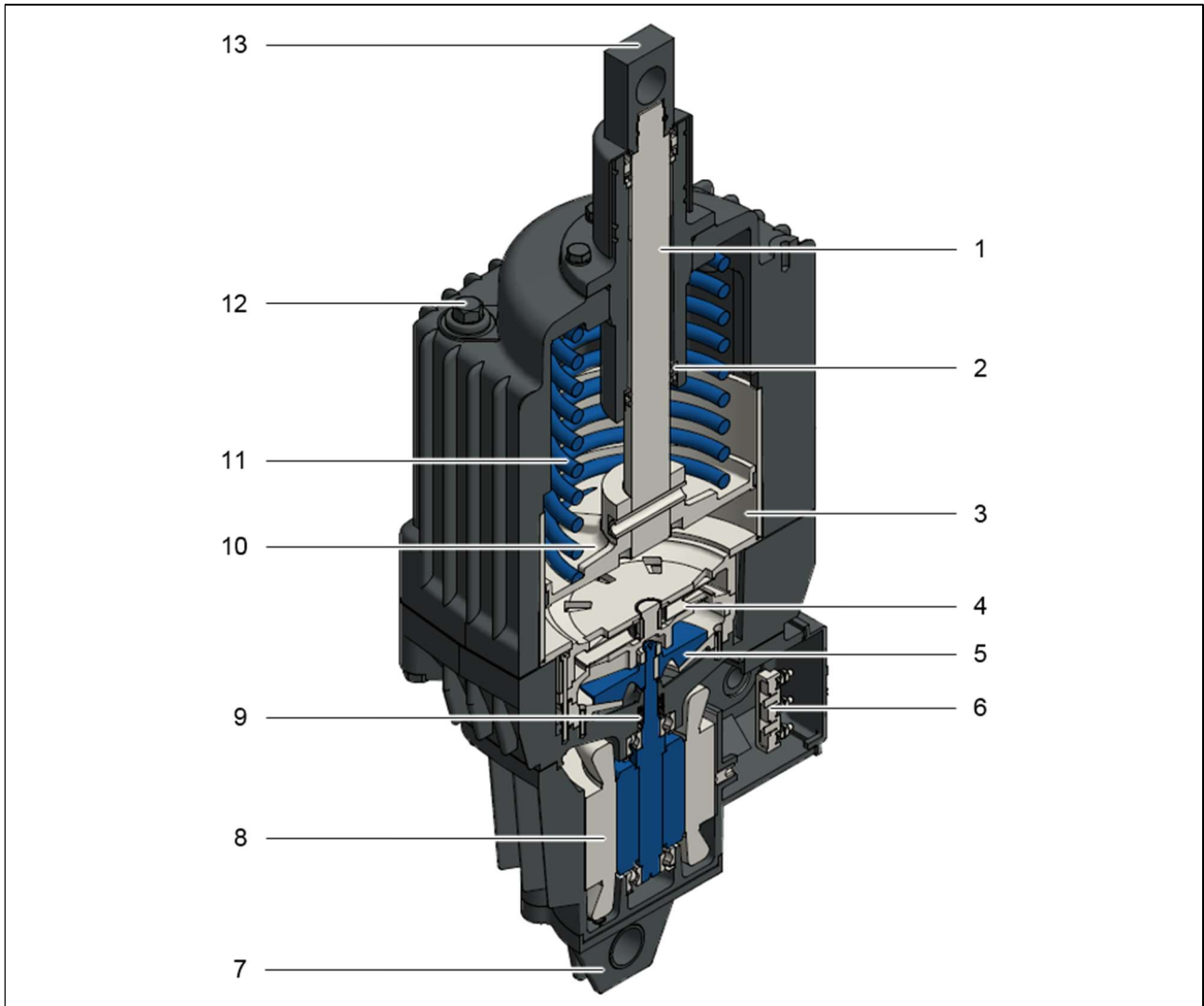

4.1.4 Type group 5

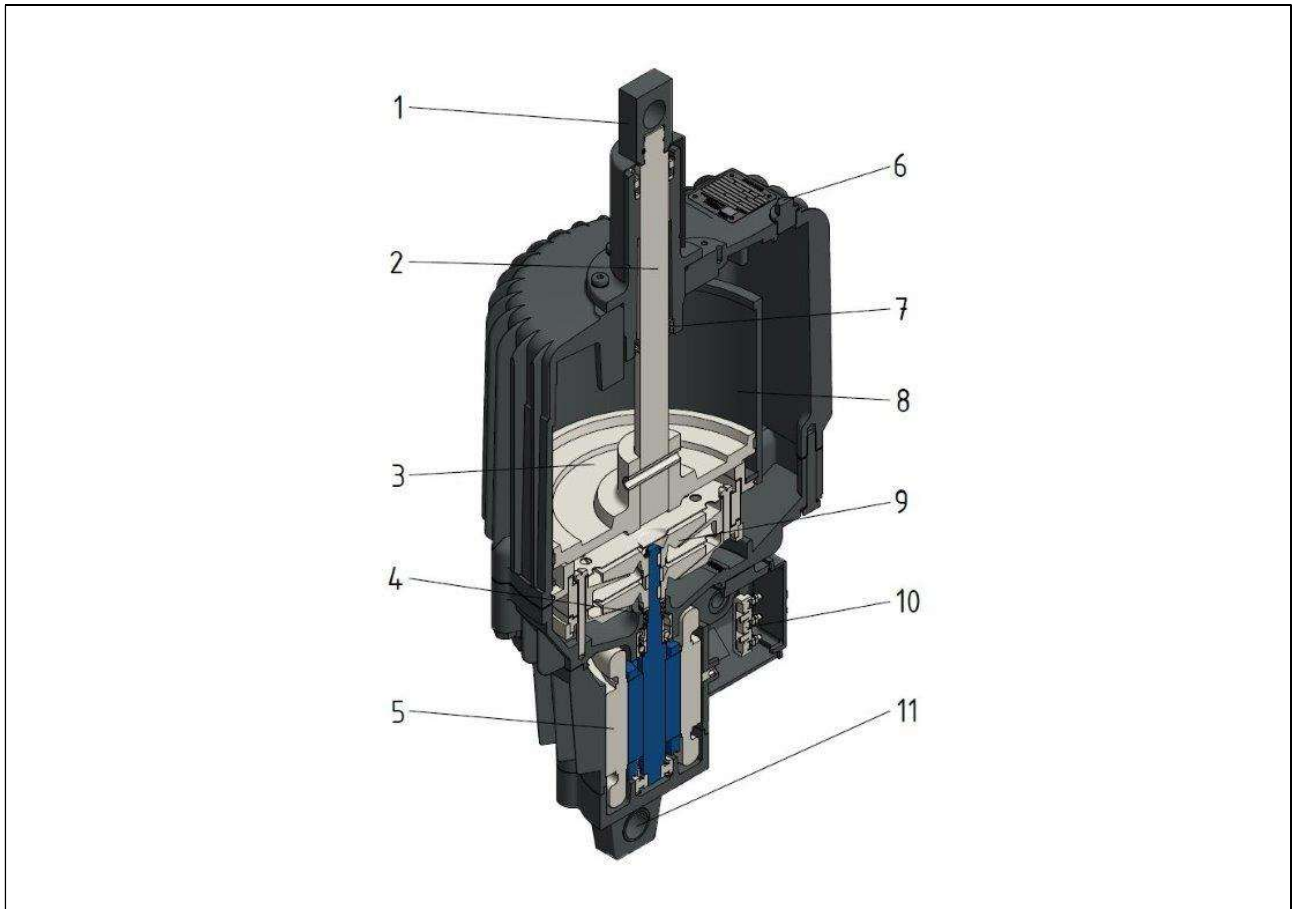

Figure 14: ELDRO® thruster layout (example: Ed 630/9)

- | | | | |
|---|---|----|------------------------------------|
| 1 | Thrust shackle | 7 | Double seal to the hydraulic space |
| 2 | Piston rod | 8 | Hydraulic cylinder |
| 3 | Piston | 9 | Lifting/lowering valve |
| 4 | Motor shaft seal | 10 | Junction box |
| 5 | Two-pole three-phase asynchronous motor | 11 | Foot attachment |
| 6 | Oil filling opening | | |

4.2 Electrical equipment

A three-phase asynchronous motor is used as the drive (some special version also use direct current motors). The power supply is provided via screw terminals that are located in a junction box. There is an M25 x 1.5 cable infeed for cable diameters of 10 mm to 19 mm on the junction box.

4.3 Functional description

The hydraulic pump driven by the motor conveys the hydraulic medium into the space below the piston. This generates hydraulic pressure that acts outwards via the piston and lifting rod.

The piston and lifting rod move backwards after the motor is switched off either due to a force acting from the outside (brake weight, brake spring) or due to the integrated reset spring. The lifting force that is available to the user of the ELDRO[®] thruster is therefore always the difference between the generated hydraulic force and any external or internal counterforce.

The lifting and lowering times depend on both the load and the viscosity of the hydraulic medium, which is in turn affected by the ambient and operating temperatures. In the versions with lifting, lowering or lifting and lowering valves, the setting/resetting speed of the lifting rod and therefore the lifting and lowering times can be adjusted infinitely within a specific range.

If the piston is in the limit position (e.g. in continuous mode S1), the motor's power consumption reduces due to hydraulic laws. This prevents the ELDRO[®] thruster overloading and a thermal protective switch is therefore not required.

5 Transport and storage

5.1 Transport

CAUTION

The ELDRO® thrusters weigh between 10 and 70 kg

Risk of injury when lifting the load manually

- Use suitable lifting equipment (e.g. crane).
- Never remain below suspended loads.
- Use a transport aid (e.g. lifting carriage) with sufficient load bearing capacity.

CAUTION

Falling ELDRO® thruster

Risk of injury due to a falling ELDRO® thruster during transport.

- Wear safety shoes

NOTE

Do not damage the fastening eyes and the lifting rod when setting down. The lifting rod must be protected in a suitable way.

The ELDRO® thrusters are packed so that transport damage will not occur under normal transport conditions. The packaging requires corresponding labels

The delivery must be checked for transport damage and completeness immediately upon receipt.

If there is clearly visible transport damage, proceed as follows:

- Do not accept the deliver or accept it with reservations.
- Note the extend of the damage on the transport documents or on the carrier's delivery note.
- Declare the faults.

Declare every fault as soon as it is discovered. Claims for damage can only be made within the legal warranty period.

5.1.1 Transport sketch

Attach a suitable load carrying thruster to the attachment point to transport using lifting gear.

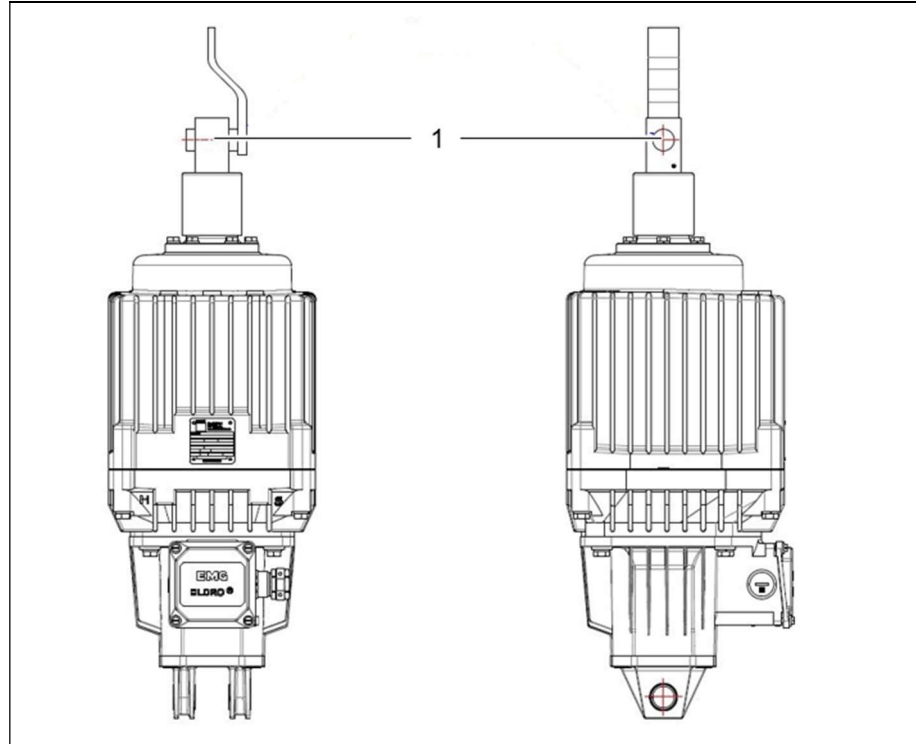

Figure 15: Attachment point

1 Attachment point

5.2 Storage

The ELDRO® thrusters can be transported or stored upright or lying down until commissioned. After storing for more than 6 months, we recommend storing the ELDRO® thrusters upright. Even though the thrusters are basically suitable for installation outdoors, we recommend taking protective measures against the effects of weather while storing.

NOTE

If stored for an extended period, the regulations for storage conditions and storage periods for rubber materials and moulded items must be observed with regard to sealing. Even when installed, the seals that were stored for too long lose their elasticity and therefore their full function.

6 Assembly and installation

The following safety regulations must be adhered to before beginning any work on ELDRO® thrusters:

- Ensure that the industrial system is shut down
- De-energise the system
- Safeguard the system to prevent it being switched on again
- Test to ensure a de-energised state
- Earth and short-circuit
- Cover or isolate adjacent live parts

6.1 Assembly

The ELDRO® thruster may only be assembled by specialists (e.g. industrial mechanics/electricians) with many years of experience.



WARNING

Cylinder movements

Risk of crushing between surrounding hindrances and the cylinder or connected components.

- When assembling, ensure sufficient free space to prevent crushing.
- Take alternative measures to safeguard this hazard point.



WARNUNG

Hot surface

Risk of burns on the housing surface

- Avoid touching the housing surface during operation. This must be ensured by the positioning of the device. If this is not possible, appropriate labeling must be used.
- Wear heat-resistant protective gloves.

 **CAUTION****The ELDRO® thrusters weigh between 10 and 70 kg**

Risk of injury when lifting the load manually.

- Use suitable lifting equipment (e.g. crane).
- Never remain below suspended loads.
- Use a transport aid (e.g. lifting carriage) with sufficient load bearing capacity.

 **CAUTION****Sudden power failure or switch-off due to any c springs, brake springs, brake weights that may be installed or due to other external influences**

Risk of crushing due to the lifting rod.

- Before removing the ELDRO® thrusters, the downstream drive must be secured, as the lifting rod retracts automatically.

NOTE

The lifting rod must not be damaged or contaminated (e.g. by paint as a result of painting the entire system). A failure to observe this will destroy the lifting rod.

NOTE

The fastening bolts on the foot hole and the lifting rod must be secured reliably to prevent them slipping out (e.g. using cotter pins).

NOTE

The ELDRO® thruster must not be subjected to any loads at an angle to its working direction. If installed upright, there must be no additional load beyond its own weight.



When replacing old ELDRO® thruster versions with thrusters with the current version, the manufacturer must be contacted due to the different installation dimensions.

6.1.1 Permissible installation positions

ELDRO® thrusters may be installed vertically, horizontally and in angled positions in accordance with the following illustration. The type plate must always be at the top. This is important, as the compensation space that is below the type plate must always be at the top.

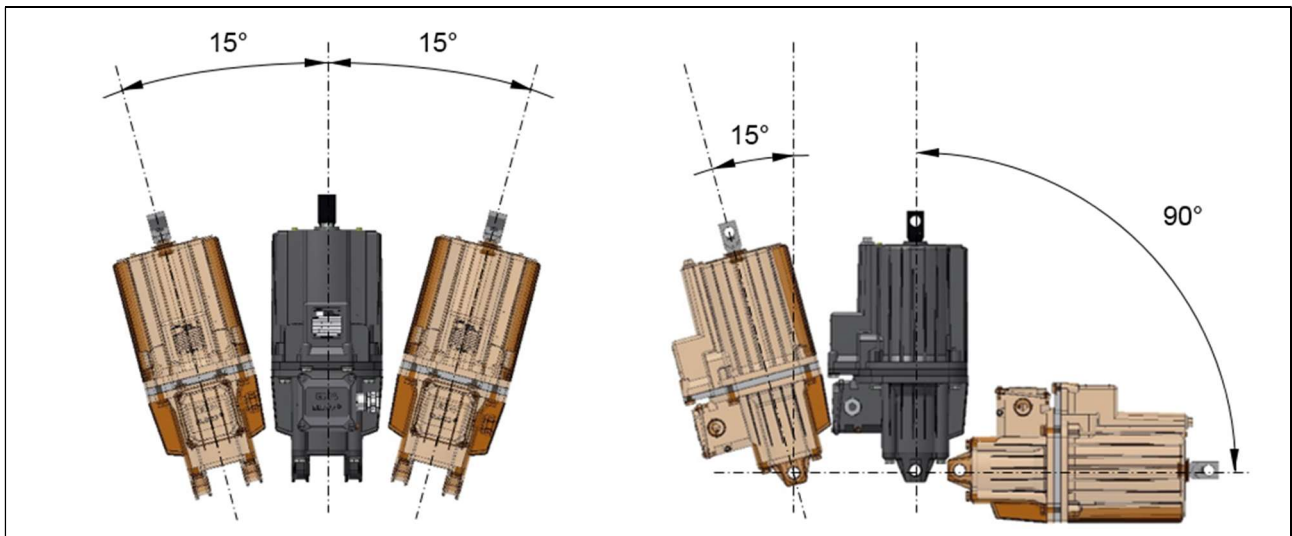

Figure 16: Permissible installation positions



If a horizontal installation position with the junction box arranged on the side or underneath is required due to the space available for example, the manufacturer must modify the ELDRO® thruster.



The Ed 350 ELDRO® thruster type must not be installed horizontally!

6.1.2 Installing the ELDRO® thruster

To attach the ELDRO® thruster, there are fastening eyelets on the motor housing and holes in the lifting rod, which can be used with suitable bolts to establish the connection to the equipment to be operated (e.g. brakes).

The diameter and length of the required bolts are specified in the dimension table (⇒ Technical data chapter, Dimensions section).



When selecting or measuring the bolts (by the customer) the required pivoting ability of the ELDRO® thruster must be observed.

The ELDRO® thruster is installed in the following steps:

- Use lifting gear to move the ELDRO® thruster to the required installation location.
- Grease the bolt slightly in order to prevent it rusting tight.
- Insert the bolt into the foot hole.
- Insert the bolt into the thrust shackle hole.

NOTE

Both bolt axes must be parallel as otherwise, the lifting rod jams and the thruster's free power development is not guaranteed.

- Use cotter pins or similar to secure the bolts to prevent them slipping out.

6.2 Electrical connection



DANGER

Live components

Fatal electric shock or serious burns

- Work on live components may only be performed by electricians.
- When performing any work on electrical components, the five safety rules must be adhered to:
 - 1. Disconnect from the electrical supply
 - 2. Safeguard to prevent a restart
 - 3. Test to ensure a de-energised state
 - 4. Earth and short-circuit
 - 5. Cover or isolate adjacent live parts
- The earthing conductor must always be connected before all other cables.
- Electrical power may only be supplied once the earthing conductor is connected.

Standard requirements must be observed when connecting the ELDRO® thruster.

Before connecting, check whether the mains voltage and the mains frequency correspond to the specifications on the type plate.

6.2.1 Junction box and terminal diagram

6-pin terminal board

Terminal diagram:

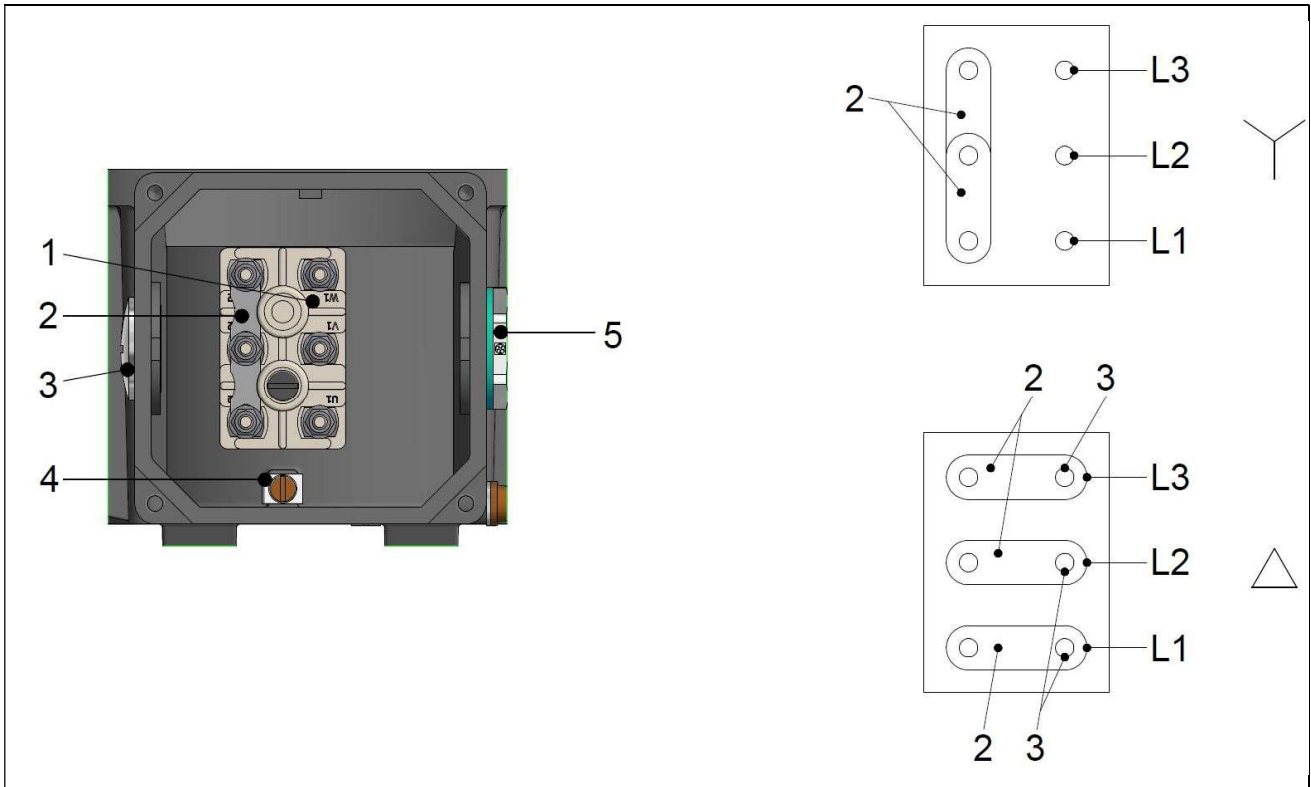

Figure 17: 6-pin terminal diagram

- 1 Connection terminals for the motor
- 2 Bridge
- 3 Blank plug
- 4 Earthing conductor terminal
- 5 M25-x-1.5 screw connection

- Δ Delta connection
- Y Star connection (condition as delivered)

9-pin terminal board with heating

Terminal diagram:

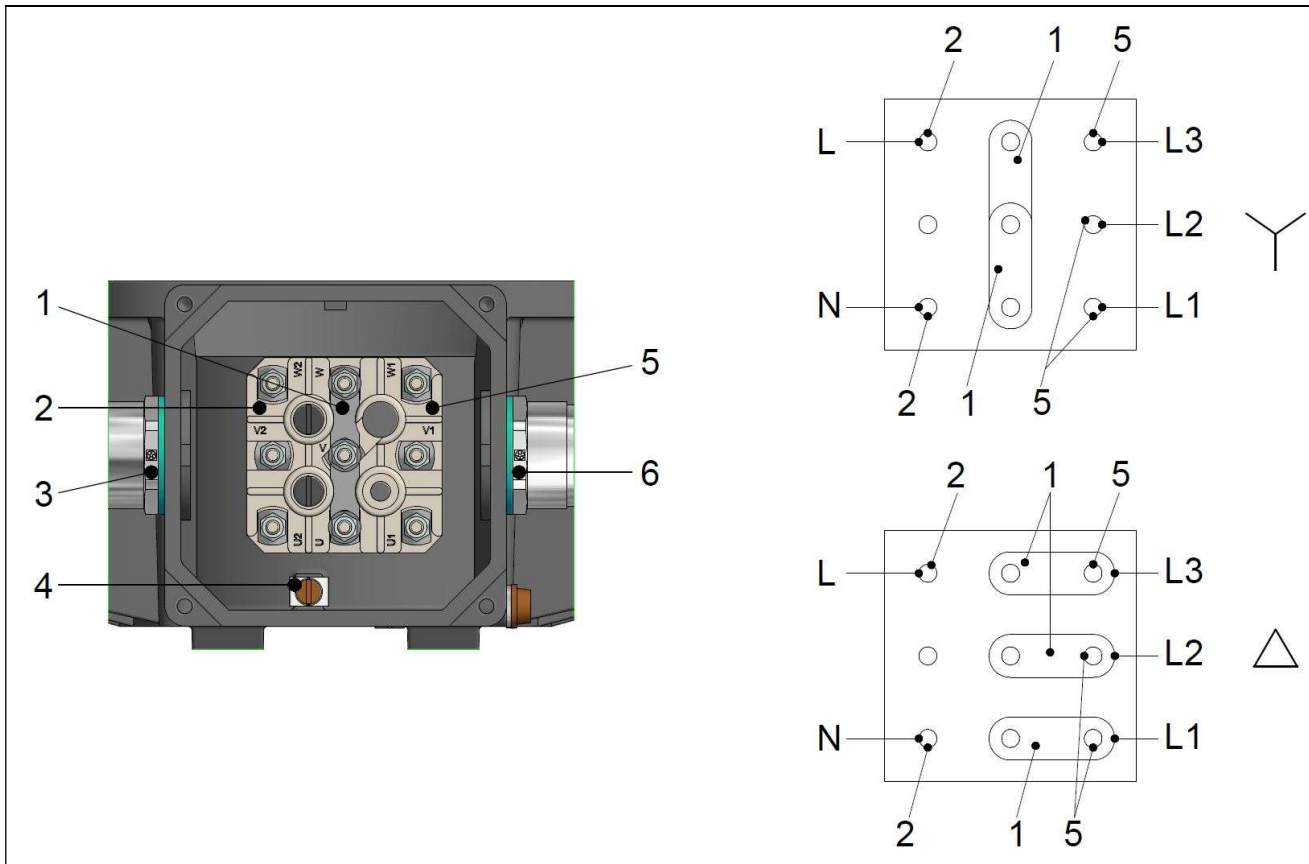

Figure 18: 9-pin terminal diagram with heating

- | | |
|--|--|
| 1 Bridge | 5 Connection terminals for the motor |
| 2 Connection terminals for the heating | 6 M25-x-1.5 screw connection for motor cable |
| 3 M25-x-1.5 screw connection for heating cable | Δ Delta connection |
| 4 Earthing conductor terminal | Y Star connection (condition as delivered) |

9-pin terminal board without heating

Terminal diagram:

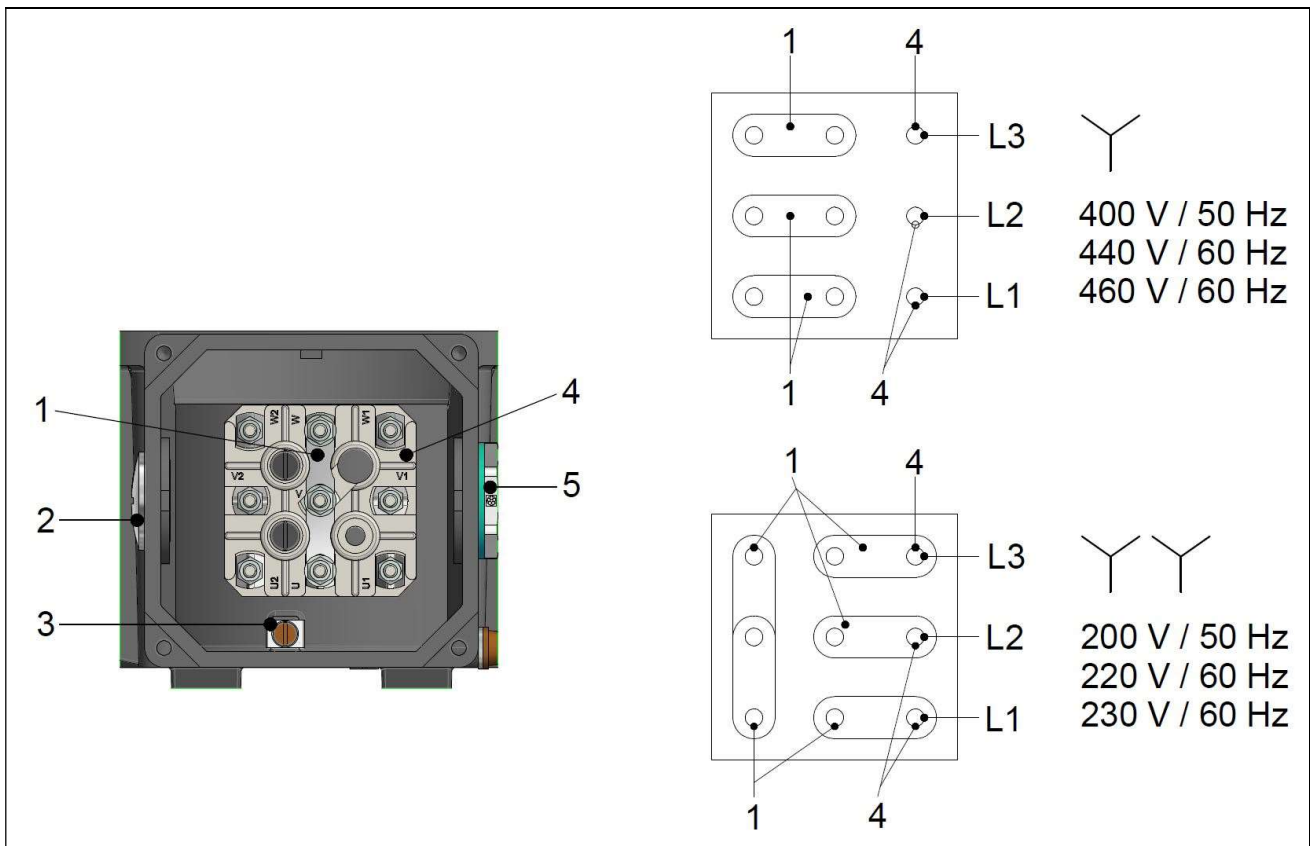

Figure 19: 9-pin terminal diagram without heating

- 1 Bridge
- 2 Blank plug
- 3 Earthing conductor terminal
- 4 Connection terminals for the motor
- 5 M25x1.5 screw connection for motor cable
- Y Star connection (condition as delivered)
- YY Double star connection



If required, the motor can also be operated with a double star connection YY by reconnecting the bridges (2).

6.2.2 Earthing conductor connection

NOTE

If the external earthing conductor connection is used, the thruster's pivoting ability and the surface temperature must be considered.

- The earthing conductor must always be connected before all other cables.

There is one earthing conductor in the junction box (⇒Junction box and terminal diagram section) and one in the immediate vicinity of the junction box on the outside of the ELDRO® thruster. The earthing conductor must be installed on the ELDRO® thruster in accordance with the applicable standards. The purpose of the earthing connector is to reduce the contact voltage in the event of coil or insulation damage to a safe amount and to switch the system off in conjunction with monitoring equipment. This can only be achieved by measuring the earthing conductor sufficiently, installing it properly and ensuring that it is intact.

6.2.3 Power supply connection

NOTE

Before connecting, check whether the mains voltage and the mains frequency correspond to the specifications on the type plate.

Always keep the junction box clean.

Check that the sealing elements on the junction box are intact and tight.

Always lock the junction box cover after connecting.

The M 25x 1.5 cable insert must be provided by the operating company properly in accordance with the IP protection class specified on the type plate.



Due to hydraulic laws, the motor's power consumption reduces when the piston has reached the limit position. This prevents an overload. A thermal protective switch is therefore not required. If a motor protection switch is used to safeguard the ELDRO® thrusters despite this, we recommend adjusting the thermal overcurrent trigger to 3 times the thruster current according to the type plate.

If using a quick lowering switch (capacitors) and a motor protection switch, the overcurrent trigger must be adjusted after consulting EMG Automation GmbH.

Electrical power may only be supplied once the earthing conductor is connected and can be provided as a fixed cable if the thruster is arranged stationary.

A pivoting arrangement requires a flexible cable. A minimum cable cross section of 1.5 mm² must be provided for all thruster sizes. The connection terminals permit a maximum cable cross section of 2.5 mm². When selecting the cables, the ambient conditions (e.g. temperature, humidity) at the installation location must also be considered.

The junction box is equipped with an M25 x 1.5 cable infeed (cable diameters from 10 mm to 19 mm).

- The supply lines are always connected in accordance with the switch diagrams on the inside of the junction box cover (⇒ Junction box and terminal diagram section).
- Only connection cables with a temperature approval of at least 110°C may be used.



Unless ordered differently, all ELDRO® thrusters are wired for a star connection as delivered from the factory. If required, the user can reconnect the bridges (⇒ Junction box and terminal diagram section) to also operate the motors in delta connection. The motor's phase sequence and therefore its direction of rotation do not matter.

6.2.4 ELDRO® thrusters with additional heating

NOTE

To control the additional heating, the operating company must provide a temperature control unit that switches the heating on below an ambient temperature of -20 °C and switches it off again above -20 °C. The heating must not be switched on above -20 °C due to the risk of overheating.

ELDRO® thrusters with integrated additional heating (observe the supply voltage) are connected in accordance with the terminal diagrams located inside the junction box cover (⇒ Junction box and terminal diagram section). The cables for the motor's power supply are guided via the M25 x 1.5 screw connection. The heating's power supply is provided via the second M25 x 1.5 screw connection on the junction box.

Temperature measurement points

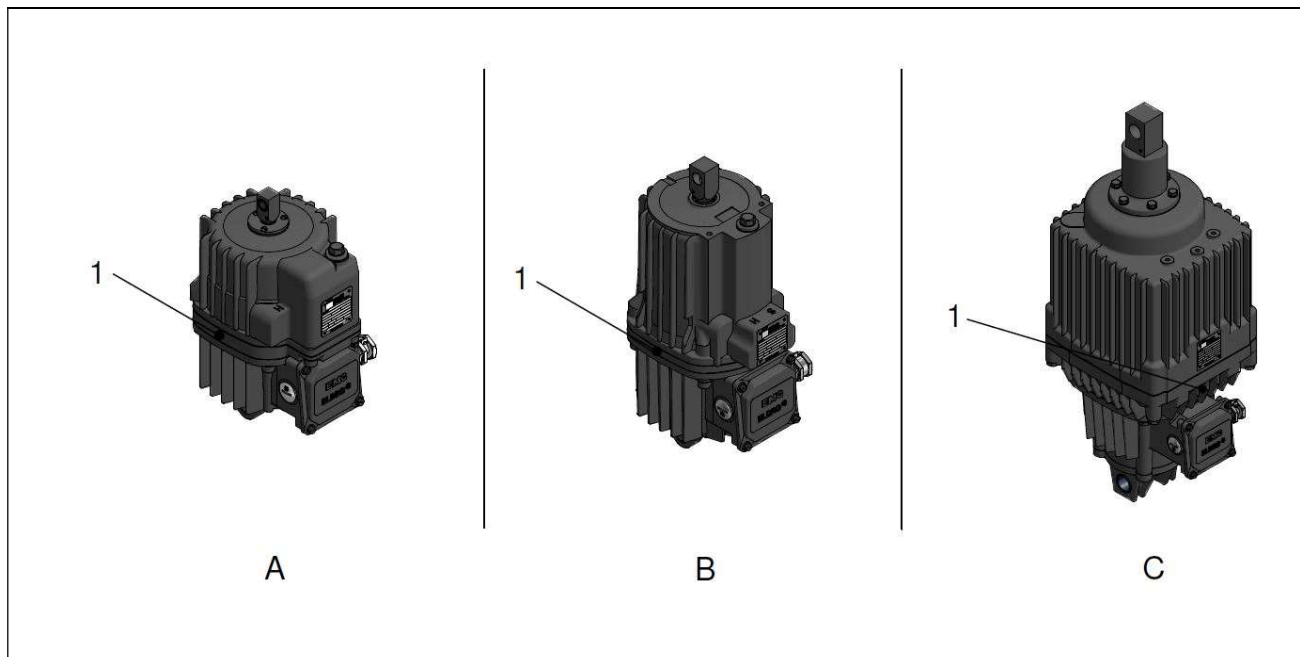

Figure 20: Temperature measurement points

A Type Ed 23/5

B Types Ed 30, Ed 50, Ed 80

C Types Ed 121/6 – Ed 350/20

1 Temperature measurement point

6.3 Adjusting the valves



In the condition as delivered, the ELDRO® thrusters are set to 5 seconds of setting time and resetting time. The setting times depend on the temperature and must be adjusted when the machine is at operating temperature.

The versions with lifting and/or lowering valves enable the lifting rod's set or reset speed (setting or resetting time) to be adjusted infinitely within a specific range. The type designation on the type plate specifies whether an ELDRO® thruster is equipped with valves (see type plate; ⇒Type designation and type key section). The H (lifting valve) and S (lowering valve) marks are embossed into the housing.

Examples for the version with valves:

- Lowering valve (S): e.g. Ed 50/6 S
- Lifting valve (H): e.g. Ed 80/6 H
- Lifting and lowering valve (HS): e.g. Ed 121/6 HS



All thrusters (apart from the Ed 630) can be equipped or modified with valves retrospectively by the manufacturer.

6.3.1 Adjustment screw installation location

The installation location for the adjustment screws is specified on the dimensional drawings (⇒Dimensions section).

Adjustment screw H for the set time (lifting time) is located to the left of the type plate below a sealing plug. See the “H” on the housing.

Adjustment screw S for the reset time (lowering time) is located to the right of the type plate and is also below a sealing plug.

See the “S” on the housing.

6.3.2 Changing the set time and the reset time

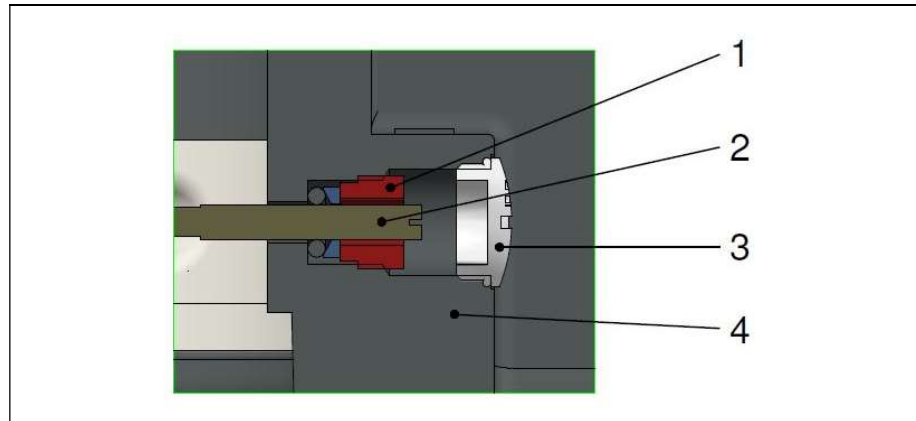

Figure 21: Lifting/lowering valve adjustment parts

- 1 Slotted nut
- 2 Adjustment screw
- 3 Sealing plug
- 4 Housing edge



Turning the adjustment screw (2) clockwise increases the lifting or lowering time.

Turning the adjustment screw (2) anticlockwise reduces the lifting or lowering time.

NOTE

When turning anticlockwise, the adjustment screw (2) must not be unscrewed further than the housing edge (4).

Release the slotted nut (1) by a maximum of a quarter turn due to the risk of losing leak-tightness.

The slotted nut must be re-tightened to hand tight after adjusting the set or reset time.

- Unscrew the sealing plug (3)
- Turn the adjustment screw (2) to set the required set or reset time
- Screw the sealing plug (3) in

6.4 Completing assembly

After completing assembly, check that the earthing conductor system is consistent.

7 Notes on operation

WARNING

ELDRO® thrusters can reach housing surface temperatures of up to 100 °C in continuous mode S1 or in switching mode S3

Risk of burns on the housing surface

- Avoid touching the housing surface during operation. This must be ensured by the positioning of the device. If this is not possible, appropriate labeling must be used.
- Wear heat-resistant protective gloves.

WARNING

Component failure

Risk of injury due to component failure

- There is the risk of individual components breaking when operating the ELDRO® thruster. The lifting force failure can pose subsequent hazards.
- The operating parameters must be adhered to.
- The ELDRO® thruster must be installed so that no forces can be applied at an angle to the working direction.

WARNING

Lifting rod movements

Risk of crushing between surrounding hindrances and the lifting rod or connected components due to the lifting rod retracting automatically due to the reset spring of the hydraulic pressure fails or the power supply is interrupted.

- Switching the motor off returns the lifting rod to the limit position.
- When assembling, ensure sufficient free space to prevent crushing or take other measures to safeguard the hazard point.
- Before removing the ELDRO® thruster, the connected unit such as the brake must be secured to prevent movement.

Never operate the ELDRO® thruster with electrical connections that are faulty or not ready for operation.

The junction box must always be locked. Access must only be granted to authorised staff who have received corresponding training and safety briefings.

If there are power supply faults, switch the ELDRO® thruster off immediately.

7.1 Checking the operating conditions prior to starting up

NOTE

When delivered from the factory, the junction box has a small bag (silica gel) in order to catch any moisture that may occur.

This small bag (silica gel) must be removed prior to commissioning.

- The ELDRO® thruster is assembled and connected according to regulations (⇒Assembly and installation section).
- The permissible voltage and frequency tolerances are adhered to (⇒Technical data chapter, Voltage and frequency tolerances section).
- The ELDRO® thruster is filled with the operating fluid prescribed for the usage conditions (⇒ Technical data chapter, Ambient temperature and installation height section) and for the version, and has the required fill level (⇒Maintenance chapter, Operating fluid section).
- The ELDRO® thruster is protected against contamination.
- The fastening bolts on the thrust shackle and the foot attachment must be secured to prevent them moving inadvertently (e.g. using locking pins).
- The axes are parallel.

8 Help with malfunctions

If used as intended, no typical malfunctions can occur on the ELDRO® thruster.

However, malfunctions can occur due to wear or misuse. Malfunctions on the ELDRO® thruster may only be rectified when the system is stopped, disconnected from the power supply and the movements have come to a standstill.

Observe the Assembly and Disassembly chapters for information on troubleshooting.

8.1 Faults and troubleshooting

Table 61: Faults and troubleshooting

Fault	Possible cause	Measure
ELDRO® thruster does not lift	Motor not running: Supply line interruption	Search for the interruption and rectify
	Motor not running: Switched off by trigger, e.g. motor protection switch	Check the motor protection switch and fuse elements
	Motor not running: Cable connections have poor contact	Clean corroded contacts
	Motor not running: Rotor is blocked in the stator within the bearing or close to the running wheel (pump)	Replace the thruster and send to the manufacturer for repair
	Thruster loaded too heavily: Too great an external load in addition to the brake and reset spring	Adjust the load on the thruster
	Lack of operating fluid	Top up the operating fluid
	Lifting rod jammed from the outside	Rectify the jam/twisting or lateral forces in the thrusters to be driven
The ELDRO® thruster lifts slowly, hesitantly, jerkily	Thruster loaded too heavily: Too great an external load in addition to the brake and reset spring	Adjust the load on the thruster
	Lifting rod jammed from the outside	Rectify the jam/twisting or lateral forces in the thrusters to be driven
	Supply line interruption (two-phase operation)	Search for the interruption and rectify
The ELDRO® thruster lifts slowly, hesitantly, jerkily	Air in the pump circuit	Actuate the thrusters a few times when stopped and top up the operating fluid if required
		Check the thruster's installation position and version

8 Help with malfunctions

8.1 Faults and troubleshooting



Table 61: Faults and troubleshooting

Fault	Possible cause	Measure
	Lack of operating fluid	Top up the operating fluid
Operating fluid escapes	On the lifting rod seal	Replace the thruster and send to the manufacturer for repair
	On the filling screw	Check the sealing ring, tighten the filling screw to a maximum of 65 Nm
	At the separation level between the hydraulic housing and the intermediate flange	Tighten the screw connection to a maximum of 53 Nm
	On the intermediate flange or operating fluid in the junction box	Replace the thruster and send to the manufacturer for repair
Rattling, metallic noise	Ball bearing damaged	Replace the thruster and send to the manufacturer for repair
Motor protection switch or fuse elements tripped	Short-circuited coil, phase leakage or short circuit	Check the motor's resistors and insulation, replace the thruster and send to the manufacturer for repair if required
Increased current consumption, cause	Between two phases: Short-circuited coil	Measure the resistance, replace the thruster and send to the manufacturer for repair if required
	Between all phases: Rotor is grinding or stuck	Replace the thruster and send to the manufacturer for repair

9 Maintenance

Maintenance work on the ELDRO® thruster may only be performed when:

- the system is stopped.
- the system has been disconnected from the power supply and secured to prevent a restart.
- the movements have come to a standstill.
- the ELDRO® thruster has cooled off.

Maintenance work may only be performed by instructed specialists (maintenance staff).

9.1 Maintenance tasks



WARNING

Hot surface

Stored residual heat poses a risk of burns if you touch the housing surface

- ELDRO® thrusters can reach housing surface temperatures of up to 100 °C in continuous mode or in switching mode S3.
- The ELDRO® thruster must cool off before starting maintenance work.



WARNING

Spraying hydraulic oil

Risk of injury (e.g. face and eyes) due to spraying hydraulic oil

- The ELDRO® thruster must be secured to prevent a restart before opening.
- Only turn the filling screw slowly.
- Only specialists are permitted to unscrew and remove the filling screw.



WARNING

Pre-tensioned reset spring

Risk of injury when opening the ELDRO® thruster due to the pre-tensioned reset spring.

- Never attempt to open the ELDRO® thruster in order to access the reset spring.
- The ELDRO® thruster may only be opened by instructed specialists with corresponding training and special tools (e.g. disassembly tools for thrusters with c springs)



WARNING

Lifting rod movements

Risk of crushing between surrounding hindrances and the lifting rod or connected components due to the lifting rod retracting automatically due to the reset spring of the hydraulic pressure fails or the power supply is interrupted.

- Switching the motor off returns the lifting rod to the limit position.
- Before removing the ELDRO® thruster, the connected unit such as the brake must be secured to prevent movement.

9.1.1 Operating fluid

ELDRO® thrusters are delivered from the factory with the EMG operating fluid that depends on the usage conditions and the required version. Specify the EMG operating fluid type that was filled in on the type plate.

The EMG operating fluids are tuned to the components used for the ELDRO® thrusters and ensure seal compatibility.

NOTE
<p>Observe the safety data sheet.</p> <p>The same type of EMG operating fluid that is already in the ELDRO® thruster must always be used to top up.</p> <p>Using an incorrect operating fluid can reduce the ELDRO® thruster's performance significantly so that the specified thruster properties are no longer reached.</p>

Table 62: Fill quantities for operating fluid

ELDRO® type	litres	ELDRO® type	litres
Ed 12/4	1,2	Ed 185/16	9,4
Ed 23/5, Ed 23/5.1, Ed 23/5.2, Ed 23/5.5	1,6	Ed 201/6, Ed 201/7, Ed 201/8	9,5
Ed 23/5 X01, Ed 25/5	1,6	Ed 201/12, Ed 201/12.1, Ed 201/12.5	9,4
Ed 30/5, Ed 30/5.1, Ed 30/5.2, Ed 30/5 X01	1,9	Ed 301/6, Ed 301/6.1, Ed 301/7, Ed 301/12, Ed 301/12.1, Ed 301/12.5	9,2
Ed 50/6, Ed50/6 X01, Ed 50/6.1, Ed 50/6.2, Ed 50/6.3, Ed 50/6.5, Ed 50/7	4,2	Ed 301/15	12,1
Ed 50/12	5,5	Ed 350/20, Ed 350/20.1, Ed 350/20 X01, Ed 350/20 X02	12,1
Ed 80/6, Ed 80/6 X01, Ed 80/6.1, Ed 80/6.5, Ed 80/7	4,2	Ed 400/6, Ed 400/7, Ed 400/8, Ed 400/8 X01, Ed 400/10, Ed 400/12	9,2
Ed 80/12, Ed 80/12.1	5,5	Ed 450/8, Ed 450/12	9,2
Ed 121/6, Ed 121/12, Ed 121/12.1	9,4	Ed 450/20	12,1
Ed 121/20	12,1	Ed 500/7, Ed 500/8, Ed 500/10	12,1
Ed 125/6, Ed 125/7, Ed 125/7 X01	4,2	Ed 501/8	12,1
Ed 185/6	9,2	Ed 630/8, Ed 630/9, Ed 630/10	12

ELDRO® thrusters are filled with EMG operating fluids HL10 for the temperature range of between -25 °C and +50 °C when delivered. Special operating fluids are required for other temperature ranges (contact the manufacturer).

9.1.2 Checking the operating fluid

 **WARNING**

Hot operating fluid

Risk of burns due to hot oil plumes when opening the filling screw when at operational heat.

- The operating fluid may only be checked, topped up or drained when switched off and cool.
- The ELDRO® thruster may only be opened at a maximum temperature of 40 °C.

NOTE

If not filled sufficiently, the thruster does not develop the full lifting force.

If overfilled, the thruster's internal pressure is impermissibly high.

The ELDRO® thrusters are filled correctly if the operating fluid level reaches the lower edge within the filling opening when the thruster is upright and the lifting rod is retracted.



Observe the disassembly instructions if the ELDRO® thruster is not installed upright (⇒ Disassembly chapter).

- Place the ELDRO® thruster upright.
- Remove the filling screw from the filling nozzle.
- Check the fill level according to the ELDRO® type and top up if required.

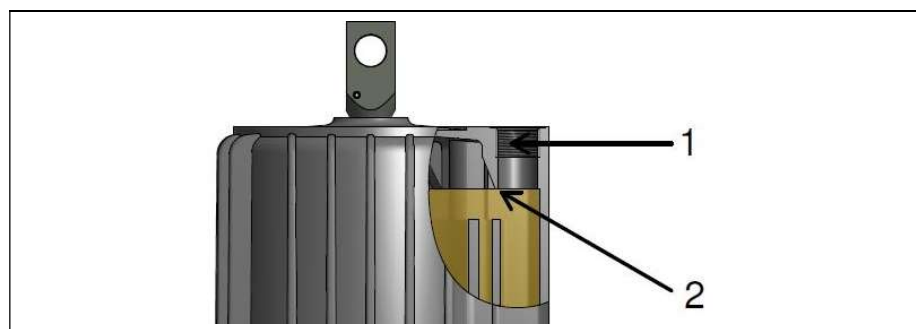

Figure 22: Operating fluid fill height

- 1 Filling nozzle
- 2 Filling nozzle bottom edge (operating fluid fill height)

Topping up the operating fluid

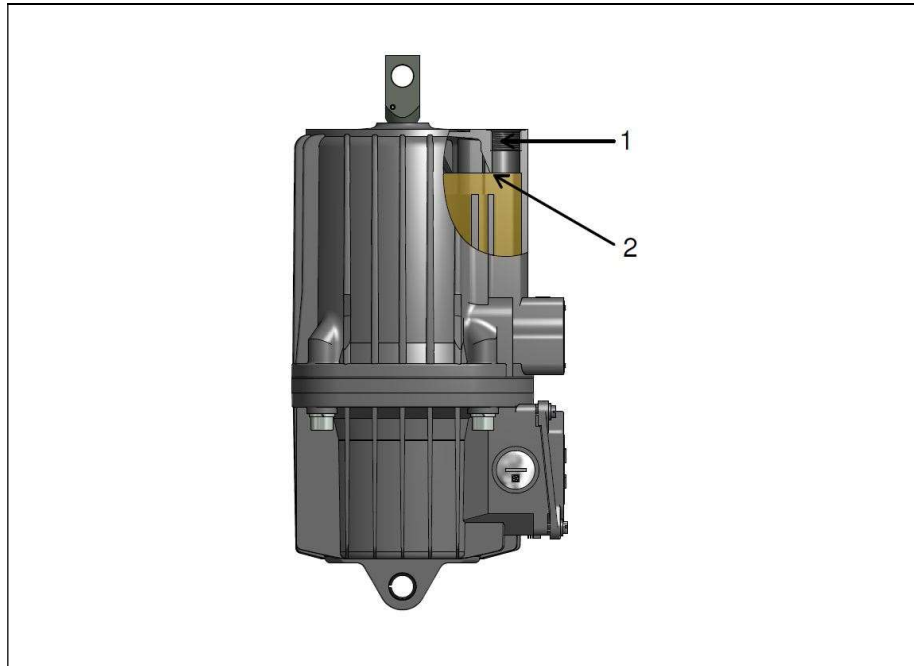

Figure 23: Topping up the operating fluid

- 1 Filling nozzle
- 2 Filling nozzle bottom edge

- Fill the ELDRO® thruster with operating fluid up to the filling nozzle bottom edge. Perform several lifting movements while doing so in order to prevent air entering the system.
- Check the fill level again and top up if required.
- Close the filling screw and, if present, the overflow screw tight (tightening torque: 65 Nm).
- Return the ELDRO® thruster to its original installation position (⇒ Assembly chapter).

9.1.3 Seals

The ELDRO® thruster must be checked for leaks at least once per year.

9.2 Maintenance schedule

Table 63: Maintenance log for ELDROclassic® lifting thrusters

ELDROclassic® type			
Serial number			
System ID			
Classification according to section 3.1 (table 1)	Low requirements	Standard	Higher requirements
	<input type="checkbox"/>	<input type="checkbox"/>	<input type="checkbox"/>

Test object	Test interval according to classification			Test performed	Test passed	Evaluation / measured values
	as required	as required	as required			
Cleaning	as required	as required	as required	<input type="checkbox"/>	<input type="checkbox"/>	
Test run	Every six months			<input type="checkbox"/>	<input type="checkbox"/>	
Visual checks				<input type="checkbox"/>	<input type="checkbox"/>	
Leaks	Annually	Annually	Every six months	<input type="checkbox"/>	<input type="checkbox"/>	
Bolt connections	Annually	Annually	Every six months	<input type="checkbox"/>	<input type="checkbox"/>	
Terminal box cover	Annually	Annually	Every six months	<input type="checkbox"/>	<input type="checkbox"/>	
Cable connections tight	Annually	Annually	Every six months	<input type="checkbox"/>	<input type="checkbox"/>	
External damage	Annually	Annually	Every six months	<input type="checkbox"/>	<input type="checkbox"/>	
Functional inspection				<input type="checkbox"/>	<input type="checkbox"/>	
Motor functions, running noises		Annually	Annually	<input type="checkbox"/>	<input type="checkbox"/>	
max. lifting path		Annually	Annually	<input type="checkbox"/>	<input type="checkbox"/>	
Terminal box and cable infeed leak tightness		Annually	Annually	<input type="checkbox"/>	<input type="checkbox"/>	
Position indicator, signals, adjustment		Annually	Annually	<input type="checkbox"/>	<input type="checkbox"/>	
Extended test				<input type="checkbox"/>	<input type="checkbox"/>	
Actuating force measurement			Every 2-3 years	<input type="checkbox"/>	<input type="checkbox"/>	
Reset force measurement			Every 2-3 years	<input type="checkbox"/>	<input type="checkbox"/>	
Power consumption measurement			Every 2-3 years	<input type="checkbox"/>	<input type="checkbox"/>	
Insulation resistance measurement			Every 2-3 years	<input type="checkbox"/>	<input type="checkbox"/>	
Coil resistance measurement			Every 2-3 years	<input type="checkbox"/>	<input type="checkbox"/>	

Test object	Test interval according to classification		Test performed	Test passed	Evaluation / measured values
Proof of insulation reliability in accordance with DIN 57530 part 1 / VDE 0530 section 17.1		Every 2-3 years	<input type="checkbox"/>	<input type="checkbox"/>	
Maintenance Replacing all wear parts (bearings, seals, operating fluids, etc.)	Recommendation: Every 5 years or after 5 million switching cycles				

Summary	Complete test passed	Repair required	Next test
	<input type="checkbox"/>	<input type="checkbox"/>	

Confirmation				
The test was performed in accordance with the manufacturer's maintenance manual.				
	Location/date	Company	Tester	Signature

9.2.1 Classification

Table 64: Classification

Classification	Low requirements	Standard	Higher requirements
by safety profile	Applications in functions and areas with low safety requirements	Applications in functions and areas with normal safety requirements	Applications in functions and areas with very high safety requirements
or by operating profile	Mainly at a standstill, operation irregular and seldom	Operated in average value ranges of the permissible operating data according to type plate	Operated in limit value ranges of the permissible operating data according to type plate
Test run	Every six months		
Visual checks	Annually	Annually	Every six months
Functional inspection		Annually	Annually
Extended test			Every 2-3 years
Maintenance		Recommendation: Every 5 years or after 5 million switching cycles	

10 Disassembly

The following safety regulations must be adhered to before beginning any work on ELDRO® thrusters:

- Ensure that the industrial system is shut down.
- De-energise the system.
- Safeguard the system to prevent it being switched on again.
- Test to ensure a de-energised state.
- Cover or isolate adjacent live parts.



WARNING

Opening the ELDRO® thrusters

Risk of injury due to tensioned c springs.

- Only service partners authorised by the manufacturer are permitted to dismantle the ELDRO® thrusters outside the manufacturer's factory.



CAUTION

Switch-off due to any c springs, brake springs, brake weights that may be installed or due to other external influences

Risk of crushing due to the lifting rod.

- Before removing the ELDRO® thrusters, the downstream drive must be secured, as the lifting rod retracts automatically.

10.1 Disconnecting the electrical connections



DANGER

Live components

Fatal electric shock or serious burns.

- Work on live components may only be performed by electricians.
- First disconnect the electrical power supply.
- The earthing conductor must be disconnected after all other cables.



Observe the allocations in the terminal diagram (⇒Assembly chapter, Electrical connection section).

- First disconnect the electrical power supply.
- Disconnect the earthing conductor after all other cables.

10.2 Removal



CAUTION

Switch-off due to any c springs, brake springs, brake weights that may be installed or due to other external influences

Risk of crushing due to the lifting rod.

- Before removing the ELDRO® thrusters, the downstream drive must be secured, as the lifting rod retracts automatically.



CAUTION

The ELDRO® thrusters weigh between 10 and 70 kg

Risk of injury when lifting the load manually.

- Use suitable lifting equipment (e.g. crane).
- Never remain below suspended loads.
- Use a transport aid (e.g. lifting carriage) with sufficient load bearing capacity.

NOTE

Suitable measures must be taken to prevent the ELDRO® thrusters falling before removing them. The ELDRO® thrusters weigh between 10 and 70 kg.

NOTE

The lifting rod must not be damaged or contaminated (e.g. by paint as a result of painting the entire system). A failure to observe this will destroy the lifting rod.

Process

1. Secure the ELDRO® thrusters to prevent them falling.
2. Pull the bolt out of the lifting rod.
3. Attach the lifting gear to the ELDRO® thruster.
4. Remove the bolt from the foot hole.
5. Use the lifting gear to remove the ELDRO® thruster.

11 Disposal

11.1 Disposal consideration



WARNING

Opening the ELDRO® thrusters

Risk of injury due to tensioned c springs.

- Only service partners authorised by the manufacturer are permitted to dismantle the ELDRO® thrusters outside the manufacturer's factory.

The manufacturer can dispose of ELDRO® thrusters for a charge in accordance with the applicable terms and conditions after they have been dismantled properly.

When disposing of the ELDRO® thrusters and their process media, observe the following points:

- Observe national regulations on site.
- Observe company-specific requirements.
- Dispose of the operating fluid (oil filling), the plastic parts and the metal parts separately.
- Used process media must be disposed of in accordance with the respective valid safety data sheets.

12 Lists

12.1 Index of figures

Figure 1:	Type designation and type key	18
Figure 2:	Type plate	19
Figure 3:	Example type Ed 12/4	23
Figure 4:	Dimensional drawing – example: Type Ed 23/5	24
Figure 5:	Dimensional drawing – example: Type Ed 30/5	26
Figure 6:	Dimensional drawing – example: Type Ed 50/6; Ed 80/6.5; Ed 80/6.6	28
Figure 7:	Dimensional drawing – example: Type Ed 201/12.5; Ed 301/12.5	32
Figure 8:	Dimensional drawing – example: Ed 350/20, Ed 350/20-X01, Ed 350/20.2	39
Figure 9:	Dimensional drawing – example: Ed 350/20.1, Ed 350/20-X02	40
Figure 10:	Dimensional drawing – example: Ed 630/8, Ed 630/9, Ed 630/10	41
Figure 11:	ELDRO® thruster layout (example: Ed 23/5 C-HS)	45
Figure 12:	ELDRO® thruster layout (example: Ed 50 – Ed 80 C-HS)	46
Figure 13:	ELDRO® thruster layout (example: Ed 121 – Ed 301 C-HS)	47
Figure 14:	ELDRO® thruster layout (example: Ed 630/9)	48
Figure 15:	Attachment point	51
Figure 16:	Permissible installation positions	54
Figure 17:	6-pin terminal diagram	57
Figure 18:	9-pin terminal diagram with heating	58
Figure 19:	9-pin terminal diagram without heating	59
Figure 20:	Temperature measurement points	62
Figure 21:	Lifting/lowering valve adjustment parts	64
Figure 22:	Operating fluid fill height	72
Figure 23:	Topping up the operating fluid	73
Figure 24:	EC Declaration of Incorporation	Fehle

r! Textmarke nicht definiert.

12.2 Index of tables

Table 1:	Format conventions	8
Table 2:	Terms and abbreviations	10
Table 3:	Responsible staff	15
Table 4:	Characteristics – short lift thrusters Ed 12/4-Ed 80/6.6	20
Table 5:	Characteristics – short lift thrusters Ed 80/7-Ed 201/7	20
Table 6:	Characteristics – short lift thrusters Ed 201/8-Ed 500/7	21
Table 7:	Characteristics – short lift thrusters Ed 500/8-Ed 630/9	21
Table 8:	Characteristics – long lift thrusters Ed 50/12-Ed 301/12.5	22
Table 9:	Characteristics – long lift thrusters Ed 301/15-Ed 630/10	22
Table 10:	Ed 12/4 dimensions	23
Table 11:	Ed 23 – 1 dimensions	25
Table 12:	Ed 23 – 2 dimensions	25
Table 13:	Ed 25 – 1 dimensions	25
Table 14:	Ed 25 – 2 dimensions	25
Table 15:	Ed 30 – 1 dimensions	27
Table 16:	Ed 30 – 2 dimensions	27

Table 17:	Ed 50 – 1 dimensions	29
Table 18:	Ed 50 – 2 dimensions	29
Table 19:	Ed 80 – 1 dimensions	30
Table 20:	Ed 80 – 2 dimensions	30
Table 21:	Ed 125 – 1 dimensions	30
Table 22:	Ed 125 – 2 dimensions	30
Table 23:	Ed 50, Ed 80 – 1 dimensions	31
Table 24:	Ed 50, Ed 80 – 2 dimensions	31
Table 25:	Ed 121 – 1 dimensions	33
Table 26:	Ed 121 – 2 dimensions	33
Table 27:	Ed 185 – 1 dimensions	33
Table 28:	Ed 185 – 2 dimensions	33
Table 29:	Ed 201 – 1 dimensions	33
Table 30:	Ed 201 – 2 dimensions	33
Table 31:	Ed 301 – 1 dimensions	34
Table 32:	Ed 301 – 2 dimensions	34
Table 33:	Ed 400 – 1 dimensions	34
Table 34:	Ed 400 – 2 dimensions	34
Table 35:	Ed 450 – 1 dimensions	35
Table 36:	Ed 450 – 2 dimensions	35
Table 37:	Ed 500 – 1 dimensions	35
Table 38:	Ed 500 – 2 dimensions	35
Table 39:	Ed 501 – 1 dimensions	35
Table 40:	Ed 501 – 2 dimensions	35
Table 41:	Ed 121 – 1 dimensions	36
Table 42:	Ed 121 – 2 dimensions	36
Table 43:	Ed 185 – 1 dimensions	36
Table 44:	Ed 185 – 2 dimensions	36
Table 45:	Ed 201 – 1 dimensions	37
Table 46:	Ed 201 – 2 dimensions	37
Table 47:	Ed 301 – 1 dimensions	37
Table 48:	Ed 301 – 2 dimensions	37
Table 49:	Ed 400 – 1 dimensions	38
Table 50:	Ed 400 – 2 dimensions	38
Table 51:	Ed 450 – 1 dimensions	38
Table 52:	Ed 450 – 2 dimensions	38
Table 53:	Ed 350 – 1 dimensions	39
Table 54:	Ed 350 – 2 dimensions	39
Table 55:	Ed 350 – 1 dimensions	40
Table 56:	Ed 350 – 2 dimensions	40
Table 57:	Ed 630 – 1 dimensions	41
Table 58:	Ed 630 – 2 dimensions	41
Table 59:	Operating behaviour depending on the ambient temperature	42
Table 60:	Type groups	44
Table 61:	Faults and troubleshooting	67
Table 62:	Fill quantities for operating fluid	71
Table 63:	Maintenance log for ELDROclassic® lifting thrusters	74
Table 64:	Classification	75
Table 65:	Further applicable documents	82

13 Appendix

13.1 Further applicable documents



13 Appendix

13.1 Further applicable documents

Table 65: Further applicable documents

Document	Designation
	EC Declaration of Incorporation